



Temelsan[®]

KN-100-HBA-TOUCH BUTT WELDING MACHINE USER MANUAL



Congratulation to your new TEMELSAN Butt Welding Machine KN-100-HBA
TOUCH

INDEX

BASIC INFORMATIONS	3
APPROPRIATE USE	3
WARRANTY AND LIABILITY	4
SAFETY	4
QUALIFIED PERSONNEL	4
PLANNING AND SET-UP	4
OPERATIONS	4
SAFETY DEVICES	4
AREAS OF USAGE	5
MAINTENANCE	5
ISSUES	
SAFETY MEASURES RELATED WITH THE MACHINE	6
TRANSPORTATION - STORAGE - PACKAGING	7
STANDARD ACCESSORIES	9
OPTIONAL ACCESSORIES	9
REQUIREMENTS OF WORKING PLACE.....	9
FIRST CONNECTIONS	11
CONNECTION OF LIQUID COOLING (OPTIONAL DEVICE).....	11
POWER SUPPLY (WIRING DRAW SEE AT FOLLOWING PAGE)	12
PRESS-AIR REQUIREMENTS	14
FIRST INSTALLATION AND ADJUSTMENTS.....	16
FIRST CLEANING	16
OPERATOR PANEL	17
START-UP THE MACHINE	22
OPERATION SCREEN.....	22
CALIBRATION OF JAW SPACE	23
BASIC SETTING OF STOPPERS AND SUPPORT PLATE LEVEL.....	24
CALIBRATION OF STOPPERS	24
SERVICING THE JAWS (PLEASE SERVICE THE JAWS FREQUENTLY)	26
CLAMPING JAW GRINDING INSTRUCTIONS.....	27
INSTALLATION OF CLAMPING JAWS	27
CLAMPING DEVICE	28

MANOMETERS	29
CLAMPING PRESSURE ADJUSTMENT VALVE	30
UPSET PRESSURE	30
JAW LEVEL CALIBRATION (CLAMPING JAW ANNEALING PRESSURE POINT)	31
CLAMPING JAW CALIBRATION BY CARBON PAPER	36
OPERATING TYPE.....	39
ANNEALING PROCEDURE MANUEL & AUTOMATIC MODUS	42
PYROMETER POSITIONING	43
CENTER	44
SUMMARY OF FUNCTIONALITY TYPES.....	46
WELDING STOP POINT.....	47
PYROMETER PICKSET	48
WELDING SPEED	49
QUICK MANUAL CHART.....	50
POWER AND PRESS-AIR (MACHINE POWER AND AIR SUPPLY CHECK CHART)	51
LIST OF ALARMS AND INFORMATIONS	52
PARAMETER CHART AND MEMORY.....	53
MACHINE SERVICE	56
CLAMPING JAW SERVICING / GRINDING INSTRUCTIONS	57
SYSTEM DRAWINGS	58
SPARE PART DRAWINGS.....	72

BASIC INFORMATIONS

This manual user guide is prepared to be useful in order to get familiar with the machine and the functions of the machine. By the help of this manual guide, the operator becomes a capable to use the machine in an optimal way in order to operationalize safely, ergonomically and properly.

This manual user guide allows the operators not to take risk, minimize the idle and repair time. It also helps to increase lifetime of the machine.

This manual user guide should be kept in a proper place and be accessible easily when needed. The local regulations included safety and environmental requirements must be followed in addition to the statements based on this manual user guide.

In case of an issue, complaint, request, demand on spare parts etc. please note the following information along with the below message

Concerning following Object:

Machine Model: TEMELSAN KN-100 HBA TOUCH

Mfg. year: _____

Serial Number: _____

APPROPRIATE USE

The welding capacity for Band Saw Blades is from minimum 20x0.90mm up to a maximum 100 x1.60mm. The machine is capable to weld all kinds of band saw blades which are called carbon, wood, bi-metal, CT Work on the electrical power supply is only to be done by professional electrician.

In the event of using the machine rather than described in which case the machine would be out of warranty situation of Temelsan.

Upset welding /resistance butt welding is a welding technique that produces coalescence simultaneously over the entire area of abutting surfaces or progressively along a joint, by the heat obtained from resistance to electric current through the area where those surfaces are in contact. Pressure is applied before heating is started and is maintained throughout the heating period. The equipment used for upset welding is very similar to that used for flash welding.

Flash welding is a type of resistance welding that does not use any filler metals. The pieces of metal to be welded are set apart at a predetermined distance based on material thickness, material composition, and desired properties of the finished weld. Current is applied to the metal, and the gap between the two pieces creates resistance and produces the arc required to melt the metal. Once the pieces of metal reach the proper temperature, they are pressed together, effectively forging them together. You will be faced with technical words like Upset Pressure, Weld-Space, Welding-Ready Position. This will be explained later in this Manual.

(Some Text here is copied from Wikipedia, which explains very well the Butt Welding procedure, many thanks to the writer)

WARRANTY AND LIABILITY

In the event of involving a personal injury or physical damages are not covered by the warranty if the following events occur as below.

- Using the machine for a purpose rather than intended
- Technically, improper installation, start-up operation or maintenance of the machine
- In the act of using the machine while any of safety equipment is a broken or protective device inappropriately running.
- Making constructional changes on running parameters.
- Insufficient control of abrasion parts
- Inappropriate repairs
- The catastrophic failures due to the action of foreign objects / Bodies and excessive force applied

SAFETY

Below safety requirements must be applied without skipping anything and priority case to carry out.

QUALIFIED PERSONNEL

Certain tasks must be carried out on the machine by a professional qualified personnel. Not third parties neither the children should be near the machine working area.

PLANNING AND SET-UP

Planning, transportation, installation, programming, start-up, maintenance, repairs and other works must be done by qualified personnel. Authorized technician must check it also.

The following matters must be noted:

- Technical data and details concerning the permissible use of the machine and its accessories.
- General and specific local preparation and safety measures.
- Personal usage and the use of general safety equipment must be related the norms.
- Especially listed on this manual guide but specifically not listed in the operating instructions that has been explicitly forbidden. Such as a handicapped to use the machine is such cases it is necessary to contact the manufacturing company.

OPERATIONS

Dangers hidden in disregards of safety regulations.

SAFETY DEVICES

The machine is equipped with the safety devices corresponding to current state of the art. In the matter of safety equipment, the machine may not be disabled, removed, dismantled, damaged. It applies in particular to:

- Safety switches (Emergency Stop Button)
- Electrical and electronic fuses

AREAS OF USAGE

The butt-welding machine Temelsan KN100-HBA TOUCH is used for low-alloyed and high-alloyed steel bands and band saw blades or bi-metal or carbide tipped band saw blades.

The welding capacity for Band Saw Blades is from minimum 20 x0.90mm up to a maximum 100 x1.60mm. The machine is capable to weld all kinds of band saw blades which are called carbon, wood, bi-metal, CT Work on the electrical power supply is only to be done by professional electrician.

The machine is a single piece and no need to be assembled.

The machine can be set-up by the customer's own staff if officially approved by Temelsan.

Please read the following sections thoroughly and carefully before the initial start-up and ensure that you clearly understand it.

MAINTENANCE

In order to insure a safe operation on the machine and prevent accidents, the job listed in the section "Servicing" must be carried out regularly. If the owner of machine is not in a position to do that also must be arranged by an authorized service agent.

ISSUES

The machine must be switched off at once in case of any problem occurs during the operation and then locked for not being restarted accidentally by an unauthorized person.

The machine must be switched off in this case.

- Unusual sounds, vibrations, smells
- Unusual operations on the monitoring device
- Increased temperatures or power consumption
- Unusual reaction during the manual or automatic operation
- Strange behavior and error messages displayed



WARNING!

Only suitably qualified personnel must service the machine!



EMERGENCY

ATTENTION!

Note the following at emergent cases (fire, water, explosions, breakage):

- Cut the machine off from the mains power supply at an external main switch or external fuses
- Switch off the compressed air supply
- Use the fire extinguishers of a suitable type to deal with the fire

SAFETY MEASURED RELATED WITH THE MACHINE**WEAR PROTECTIVE GLASSES!**

Welding beads produced during welding work could damage your eyes.

**WEAR GLOVES!**

The sharp edges of the blades can cause hand injuries.

**DANGER OF FIRE!**

Easily inflammable materials could be set alight if they come in to contact with welding sparks. Kind of inflammable materials should keep far away from welding area constantly during the operation!

**SWITCH OFF THE MACHINE!**

Cut off machine from the main supply before carrying out setting-up maintenance and servicing work on the machine.

**DANGEL OF BEING CRUSHED!**

There is a degree of danger if being crushed when in the proximity of the clamping jaws during inserting parts. There is a degree of danger being crushed between the clamping jaws during the setting-up operations.

**ATTENTION!**

It's dangerous when contacting parts of the power supply, control and transformer.

**IN CASE OF EMERGENCY;**

Push the emergency stop button.

The emergency stop button is to use by emergency issues only!

TRANSPORTATION - STORAGE - PACKAGING

The machine may not be handled with special care in transport so as to prevent damage from impacts to careless loading and unloading. The measures listed below are essential. The following measures that must be taken only cover the transport within the company. Road, rail, airline transport and sea transport require additional measures to be taken.

Transport in assembled state (see figure below)

- Use only the lifting eyelets for transport by crane (Picture below)

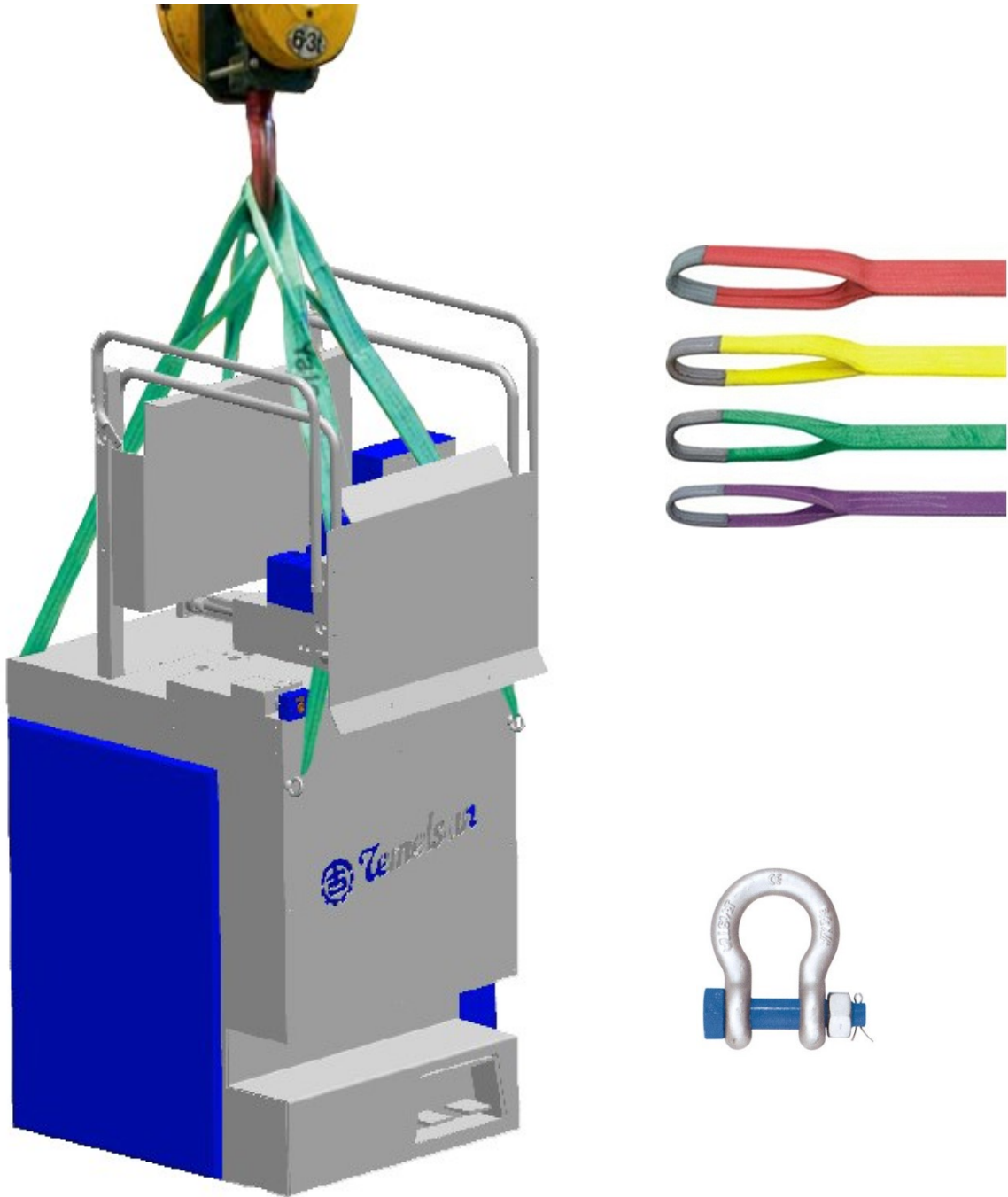

- The use by forklift (pictured blow)



Attention:RISK OF TIPPING OVER

The higher center of gravity requires a special view for transportation even the Machine should be fixed by screws to the pallet.

STANDART ACCESSORIES

500 Bar	Strong Hydro-Pneumatic clamping system
20-100mm	Width Bi-Metal and CT-Band welding capacity
25-120mm	Width Wood-Band welding capacity (by additional jaws 70mm width)
One type jaws	Both side usable and turn able for small widths
Adjustable	Numeric stoppers for cambered band saw blades
Digital Display	With touch-screen control
3 Program Memories	For 3 fully range of band saw blade dimensions
High Pressure Air	Cleaning system (air blow off), nozzles positioned inside the clamping jaws
Full Auto Annealing	Control by pyrometer 300-1300oC, swing system, measuring area 4x4mm
Pyrometer Cover	Is a well-constructed metal box with fully automatic open and close functionality; switch controlled, includes also the LED working place lamp. Digital positioning system of clamping jaws.
Air Pistol	For manual cleaning
Air Reservoir	To combine the income air capacity
Support Tools	Pre-Adjustment tools

OPTIONAL ACCESSORIES

Liquid	Cooling System
Flash (Spark)	protection cover with auto start-stop
High precision	De-Burring system
2 Set Spare	Upper and Lower Jaws (4 pcs of upper + 4 pcs of lower jaws)

Please check the Packing when arrived before unloading the machine from truck.

Do not accept the delivery if packaging is damaged or broken by transportation.

In case of broken or damaged packing of machine, it's possible with agreement of Transportation Company to unpack and check the machine condition before down loading

As soon you unload the machine, you accept the condition of machine, you take any responsibility for damages and eventually repairs.

REQUIREMENTS OF WORKING PLACE

- Flat and smooth ground
- Required big enough area around the machine
- Environmental conditions
- The running of the machine is not permitted if flammable liquids and objects are near to welding machine
- Enough air circulation is required
- The client is obliged to local electrical distributor notified technical requirements

RECOMMENDATION HOW TO PLACE THE TEMELSAN KN100HBA-TOUCH MACHINE

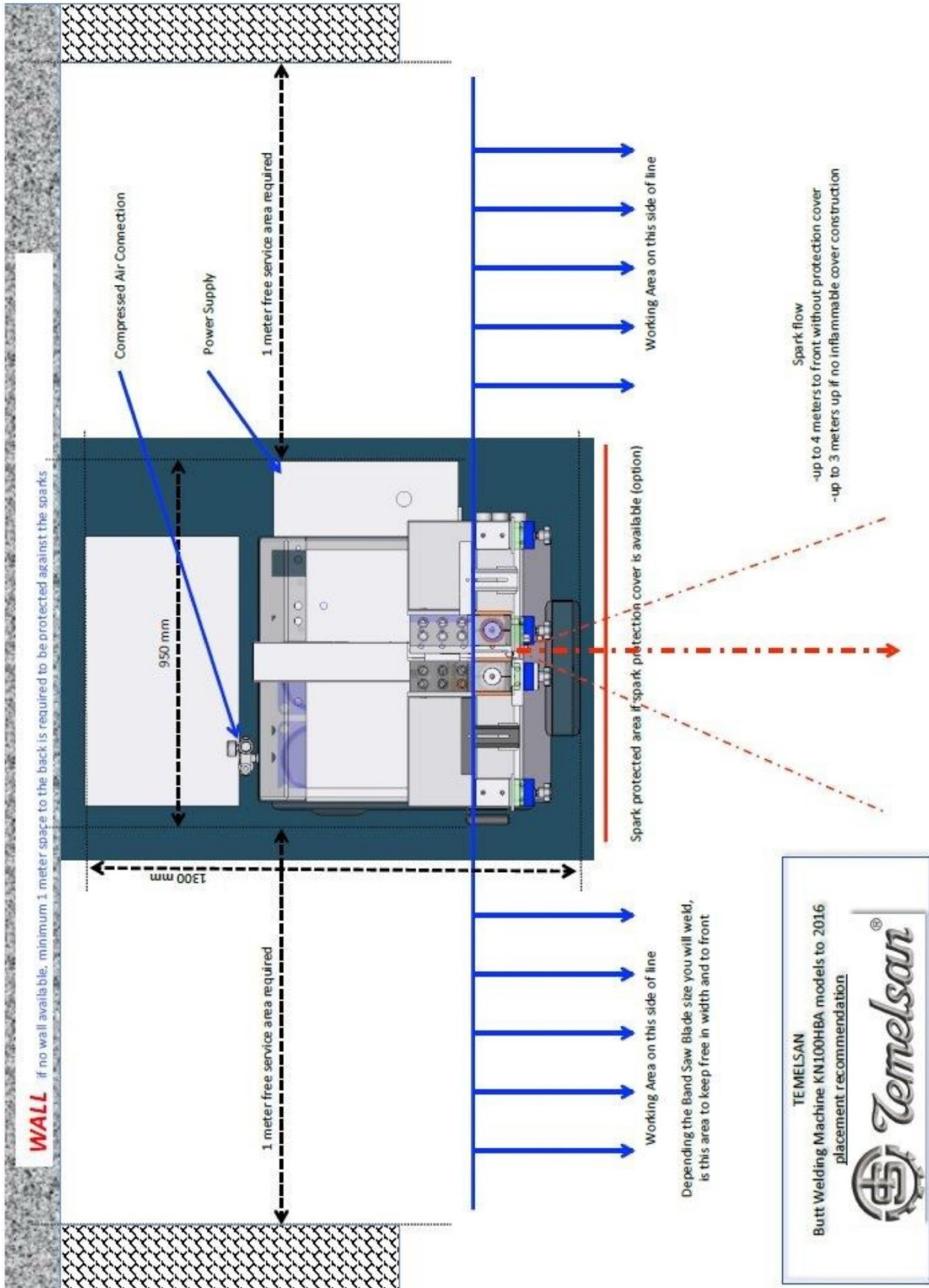

FIRST CONNECTIONS

CONNECTION OF LIQUIDE COOLING (Optional Device)

The Jaws and the transformer are heating up after any weld and annealing procedure.

Depends the number of welds and annealing during a short period and depends size of the band saw blades is the cooling time too short, the jaws and there level adjustment getting deformation and adjustment changes.

The cooling system is an separate liquid cooling system which is to position on the back of the welding machine. The liquid is an simple antifreeze pure which is used for cars. Do not use Alcohol.

The supplied Tubes have to be connected to the shot-off valves right behind the Machine and the valves have to be opened. Make sure you fill antifreeze liquid to the maximum level after connecting to welding machine and running the cooling system few minutes.

Also behind the welding machine is located an 220V plug where the cooling system have to be plugged. The 220V plug will supply power only when main power switch of welding machine is switched on, additionally the cooling system has an on/off switch.

The liquid temperature is adjustable down to 9-10°C, very important to know that the adjusted temperature should have not more then 10°C temperature different to room/working place air temperature. For example; if Room temperature is 25°C, the cooler should be adjusted not less then 15°C.

The reason is to prevent condensation of jaw blocks and transformer body. **We recommend to adjust the cooling system with 20°C**

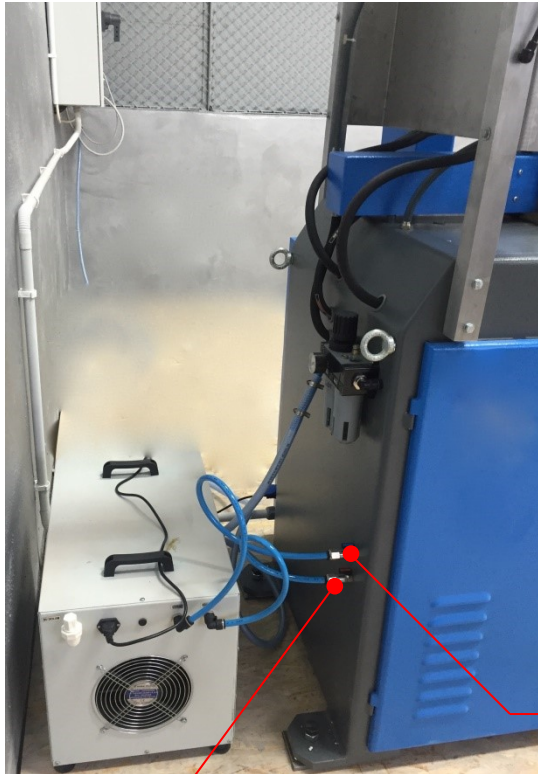

LIQUID OUT

LIQUID IN



Plug it in just behind the Welding machine

POWER SUPPLY (Wiring draw see at following page)

Make sure that the main switch of the machine is on OFF position and prevent to be turned on by an accident.

A qualified electrician must do the connection.

The input voltage (standard norm) is 400V AC (3 Phase + Neutral + Ground) 50Hz.

The input voltage (US Norm) is 600 V AC (3 phase + Neutral + Ground) 60 Hz. (optional)

The recommended fusing for power supply is **63 Amp fuse, sluggish type**

The Diameter of each wire for power supply it's very important, please use the chart by selecting the Machine Type

Do not switch ON the machine before the all setup instruction is read and work performed



ATTENTION!

Pay special attention to protect yourself from the energized cables moreover the control panel while operating the machine. Keep closed the cover of electrical control panel and do not forget to take out all the foreign objects in the cabinet which might cause short circuit.



WARNING!

- Working on the electrical power supply has to be only done by professional electrician.
- The electrical equipment of the machine must be checked regularly
- Always keep the switching cabinet locked. Access is only permitted to authorized personnel with the key or special tool.
- Remove at once any loose or worn cables
- If it is essential to work on parts carrying a current there must be a second person present to turn off the main switch in case of an emergency
- The customer is required to comply with the technical conditions and requirements of the relevant electrical power supply company

		KABLO / CABLE						
MAKİNE MODELİ MACHINE TYPE	TRAFO KVA	ŞEBEKE GERİLİMİ LINE VOLTAGE	SİGORTA GEÇİKMELİ FUSE SLUGGISH TYPE	KABLO MODELİ CABLE TYPE	KABLO UZUNLUK CABLE LENGTH	NOMİNAL KESİT NOMİNAL CROSS SECTION	DIŞ ÇAP OVERALL DIAMETER	İLETKEN TEL SAYISI VE ÇAP NUMBER OF CONDUCTING WIRE
		VOLT AC	AMPER		METER	mm ²	mm	mm
KN41 HBS	4.5 KVA	400 VAC	50	TTR	< 5	5x10	21	6
KN67 HBS	12 KVA	400 VAC	63	NYN	< 5	3x16 + 10 + 10	23	7x1,7
KN67 HBA	40 KVA	400 VAC	63	NYN	< 20	3x25 + 16 + 16	25	7x2
KN100 HBA	63 KVA	400 VAC	63	NYN	< 50	3x35 + 16 + 16	32	7x2,4

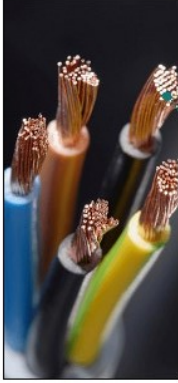



TTR

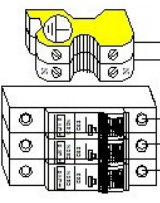

NYN







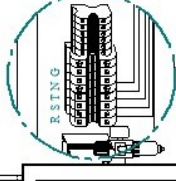

RSTNG

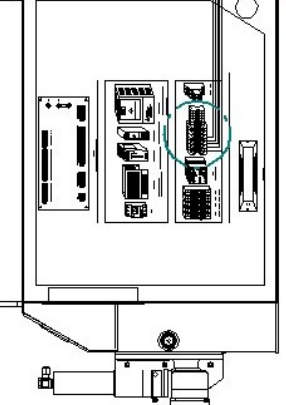

MAX 5 METER
NYN 3X16+10+10
(KN41 HBS TTR 5X10)

PRESS-AIR REQUIREMENTS

The machine needs dry and clean air pressure, which needs 7-8 bars. The reservoir capacity of the air compressor should be 300-500 liters

After some time the air becomes wet and dirty, then please clean the conditioner of air right behind the machine.

Connect air hose supply coming from the compressor through on main shot-off valve to the conditioner at the rear side of the machine. We recommend to have positioned a shot-off valve on the escape route or behind the machine.

As soon the compressed Air supply is connected, check and adjust the income pressure right behind the machine to 8 or maximum 9 Bar.

Machine has a Press-Air control-switch; it will give an Alarm when incoming air-pressure is too low. Following page shows an overview about Press-Air Connection.

Air Supply Check

Main Air Supply minimum 7 maximum 9 Bar

The compressor should be adjusted as starting to fill the air by 8 Bar and stop to fill by 9 Bar if Clamping Pressure does not reach the 400 Bar, the main air pressure is too low never adjust the main Air pressure over 10 Bar. Factory adjustment is 8 Bar The Tube size for Air Pressure supply is minimum 12x10 mm.

Machine can weld the smaller bandwidths by lower Air pressure but the wider bandwidths could be not welded well. In fact you limit your machine if you use low air pressure supply. Machine needs always higher Air-Pressure income then finale for Bandwidth needed.

Table for Air pressure comparison to clamping pressure KN-100-HBA TOUCH

Income Air Pressure	Created Clamping Pressure	Required Bandwidth	Clamping Pressure
5 Bar	350 Bar	20mm	250 Bar
5,5 Bar	375 Bar	27mm	300 Bar
6 Bar	400 Bar	34mm	325 Bar
6,5 Bar	425 Bar	41mm	350 Bar
7 Bar	450 Bar	54mm	400 Bar
		67mm	450 Bar
		80mm	500 Bar
		100mm	500 Bar

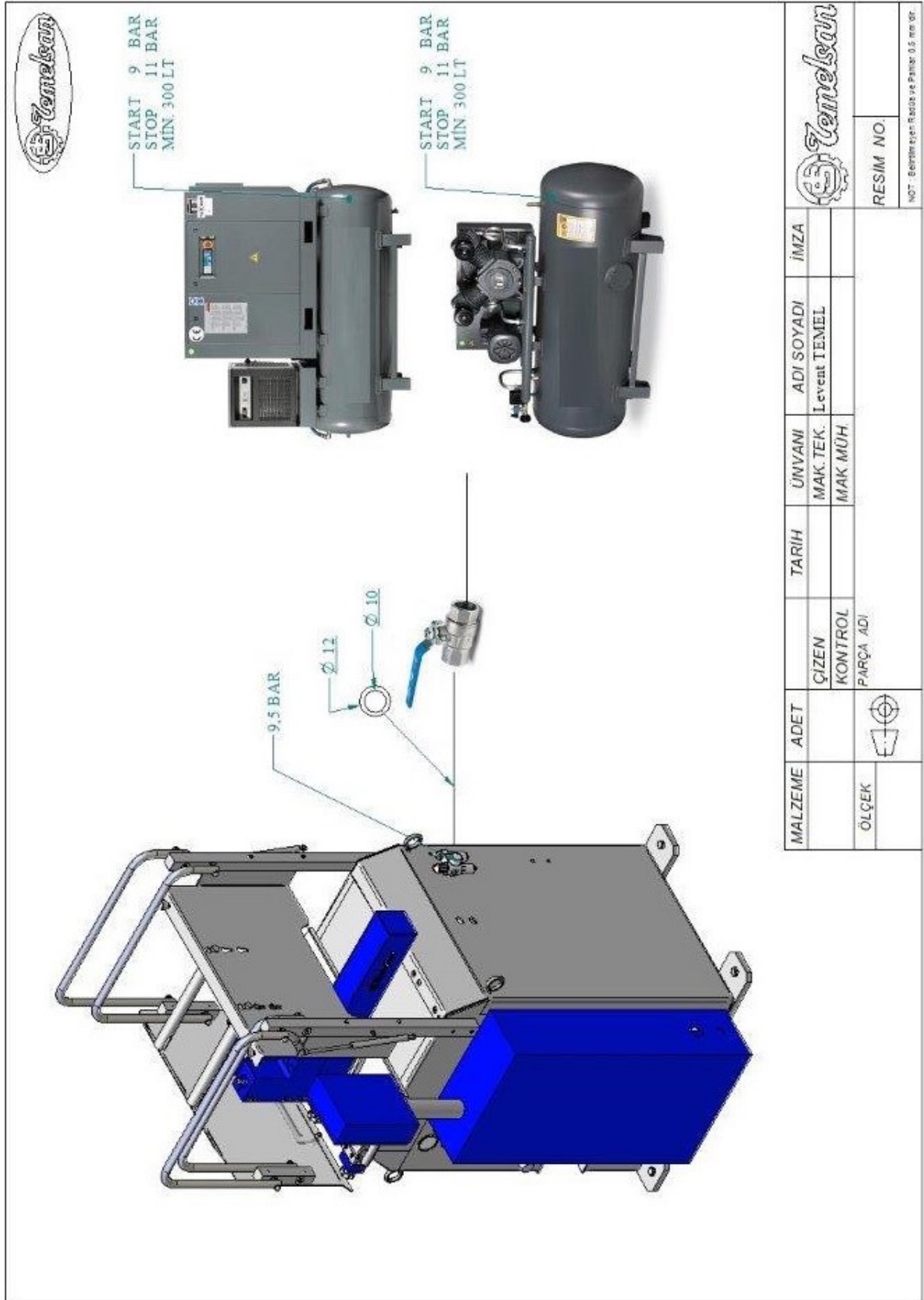

FIRST INSTALLATION AND ADJUSTMENTS

Authorized professionals, who must read this user guide, must do first installation and adjustments. In case of questions, is an immediately contact with manufacturer/supplier required.

FIRST CLEANING

Unpainted parts on the machine are slushed with conservation oil and have to be cleaned before the operation can start. Especially the jaws and around them must be cleaned properly.

Check Points

1. Power is connected through the instructions above, All fuses are ON also inside the electro cabinet
2. Air is connected and adjusted with 7 Bar (KN 100 HBA TOUCH)
3. Cooling System is connected properly (Optional device)
4. De-Burring System is available (Optional device)
5. Spark Protection Cover is available (Optional device)

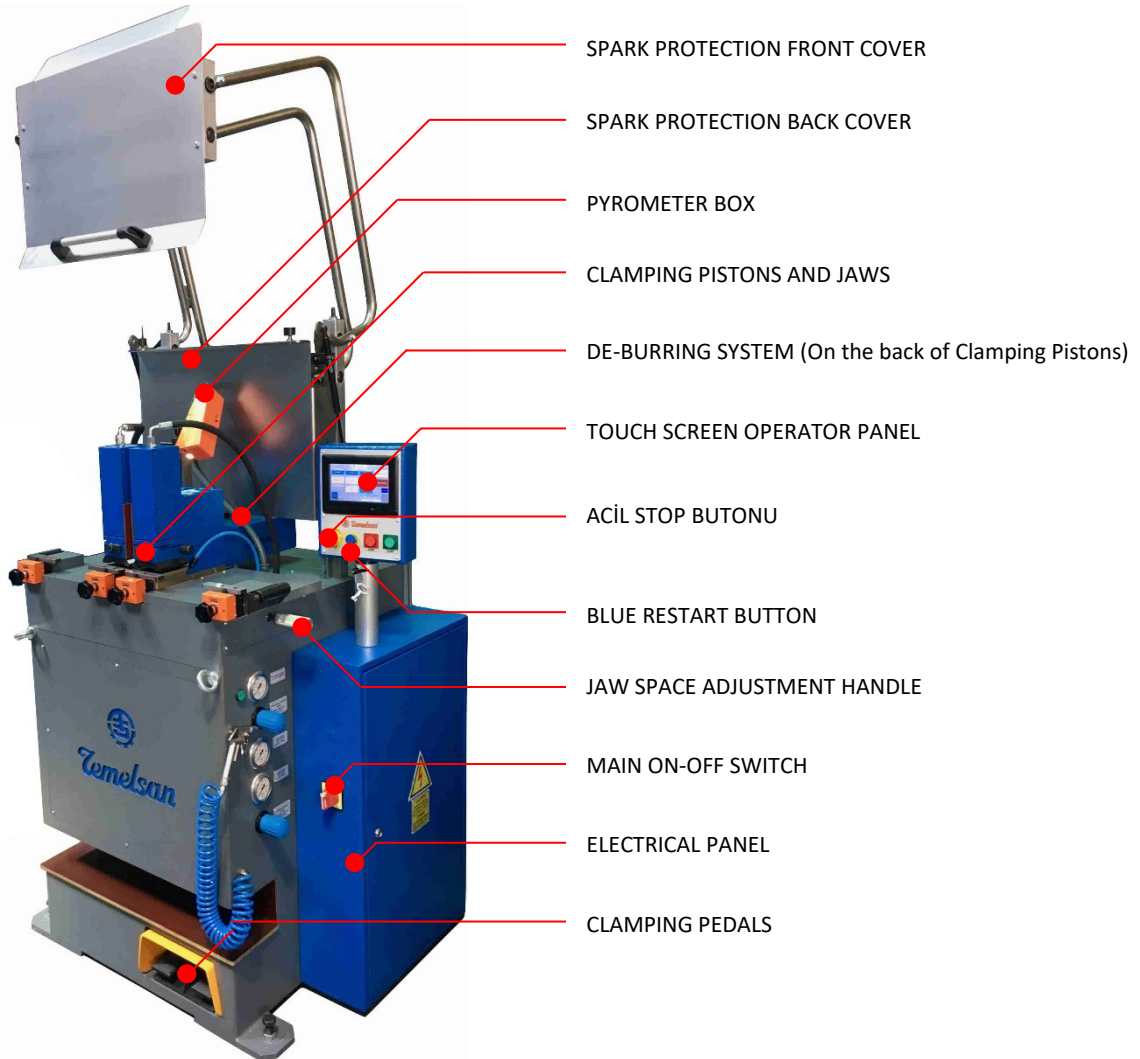

OPERATOR PANEL

The new type of KN 100 HBA Touch version has touch screen operator panel. More easy and more specific settings of welding and annealing can be done faster with touch screen panel.



DESCRIPTIONS OF WELDING SETTING SCREEN

-Select Program: This button using to select your bandsaw blade specifications. Program is running on start with the “Bi-Metal” selection and its using to weld Bi-Metal Band Saw Blades.

If click once you will see the button text will change to “Carbon” and if you will click one more time the button will show “Wood”.

If you will like to turn back on “Bi-Metal” Selection just click one more time.

-Select Bandsaw: This button is using the select bandsaw dimensions. If you click once its will appear the picture on below and you can just click on size which you want to weld.

20x0,90mm	27x0,90mm	27x1,10mm	34x1,10mm
41x1,30mm	54x1,30mm	54x1,60mm	67x1,60mm
User 1	User 2	User 3	User 4
User 5	User 6	User 7	User 8
User 9	User 10	User 11	<<<

There is a table that you can select your bandsaw before you start to make welding.

You can set to limit your selection. Also you can use the User selections to make your additional dimensions for welding.

If you want to cancel your selection you can click the “<<<” (gray button) to close this screen to turn back on main screen.

NOTE: Please contact to Temelsan Company in case you want to change your limits. Limits can't be changed by users. Limit control can be controlled or changed from Temelsan Technical Services.

-Welding Current: This button can give you a numpad to write there the Welding Current which is one of important setting for qualified welding.



When this numpad is appear please click the percentage of using the transformator.

After you click the numbers you have to click "EXE" button to confirm it.

If you want to cancel your changes please click the "ESC" button to cancel it.

If you need to change numbers you can use the "CLEAR" button to delete all numbers which is appear.

-Welding Stop Point: This button makes you adjust your welding burr size and also this is one of important parameter of welding.

After the click of this button again numpad will be appear and you have to text your numbers there to set your parameters.

-Welding Speed: This button makes you to adjust your welding speed.

After the click of this button again numpad will be appear and you have to text your numbers there to set your parameters.

-Counter: This box shows you the welding quantity per day. And every new day it's start from zero.

-Up-Side Pressure: This button make you to select for using the secondary up-side pressure or do not use it.

-Recommended J. Space (Recommended Jaw Space): This box is show you the recommended jaw space for selected bandsaw.

This recommendation is came from long experiences and we do not prefer to change it.

Anyway in case you click the button its will appear the numpad so you can change or cancel the changes.

-Real J. Space (Read Jaw Space): This box show you your real jaw space during the operation.

Real Jaw Space is connected to the Recommended J. Space screen.

In case the real jaw space will be different more than +/- 20% of recommended jaw space, welding will not start!

NOTE: Before you start to make welding operation please check the Real Jaw Space to be same with Recommended Jaw Space.

-WELDING READY: Clamping Jaws are mowing to smaller spacing for welding ready position. The control of correct positioning is the LED light for working place is going to switch ON. This is -also the position to adjust Spacing manually.

-ANNEALING READY: Clamping Jaws are mowing to wider spacing, so to annealing ready position. Jaw Spacing can be not adjusted manually.



Click here for the next page.

Next page is Annealing Settings

On the next page you can adjust your automatic and manual annealing settings.



DESCRIPTION OF ANNEALING SETTING SCREEN

-CENTER: After the welding jaws are moving on Annealing Ready position (in case if operation mode is on Automatic). While jaws are moving to Annealing position welding line should be on the middle of the jaw space. With this button you can adjust the centering of welding line on annealing position. Look at the page nr46.

After the click of this button again numpad will be appear and you have to text your numbers there to set your parameters.

-PICKSET: Depending the Band width and band thickness has to be adjusted the PICKSET for each band width and program is an different PICKSET.

The PICKSET is only active when Annealing Type is Automatic selected

After the click of this button again numpad will be appear and you have to text your numbers there to set your parameters.

START-UP THE MACHINE

(Very important to follow step by step, do not proceed to next step when check point is not confirmed for proper functionality)

1. Turn the main power switch to ON
2. Check and unlock the Emergency Stop Button (to unlock turn on Button to left side)
3. Push the Blue Start Button for Ready to Use (follow on Screen the Welding screen should start-up)

OPERATION SCREEN



4. Push on Operator Screen the Button "Welding Ready"
The right jaw should move on position and the LED light for working place located at the Pyrometer protection Box should go ON
5. Check the space between the Jaws; it should be **more than 11mm**
6. Push on Operator Screen the Button "Annealing Ready"
The right Jaw should move on position and the LED light for working place located at the Pyrometer protection Box should go OFF

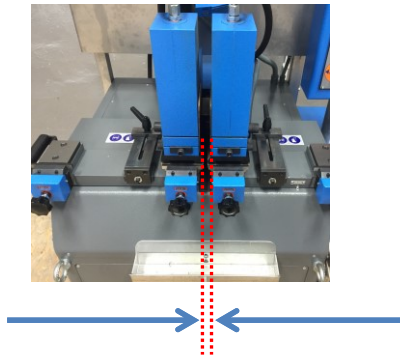

CALIBRATION OF JAW SPACE

Adjust the space of jaws by turning the hand wheel to 10mm (use a caliper) Hand Wheel can be only turned when jaws are in Welding Ready Position!

Adjust the space indicator also to 10mm by using service screen Check the indicator frequently.

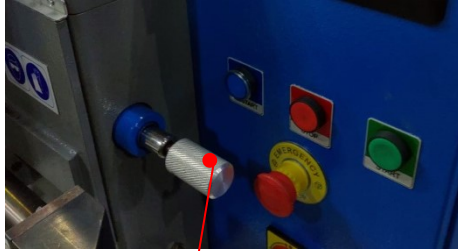

Jaw Space Adjustment Handle



Jaw Space Indicator on Welding Screen



Adjust the space between the Jaws in Welding Ready Position to a specific slot width and measure it proper.

Position on Space indicator should be same.

PLEASE CONTROL THIS FREQUENTLY!

BASIC SETTING OF STOPPERS AND SUPPORT PLATE LEVEL

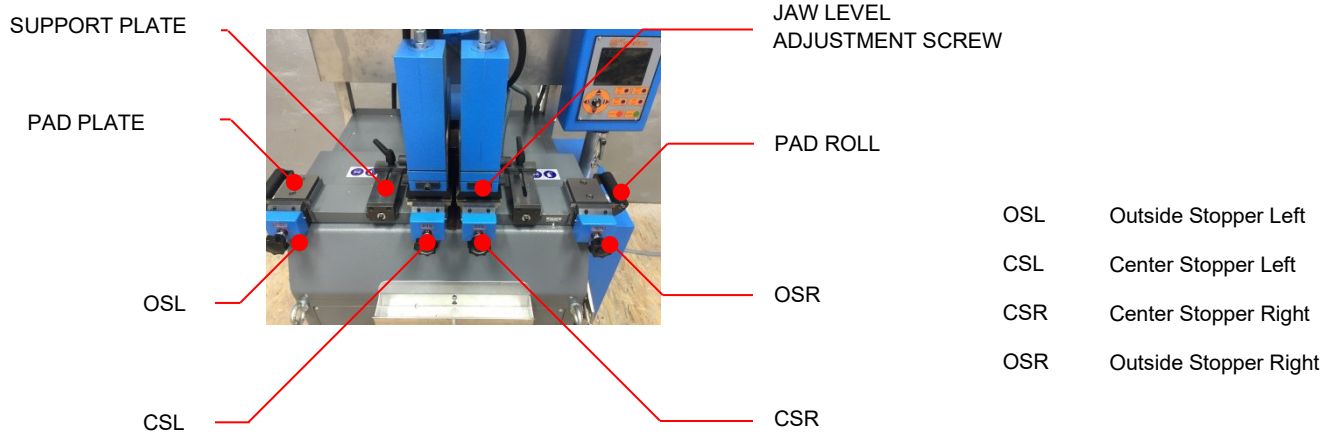

CALIBRATION OF STOPPERS

The Stoppers are the warranty for cutting edge (Teeth) in straight line.

Band Saw Blades has different height of teeth construction

Band saw blades had cambered body

The stoppers on Temelsan KN 100 HBA TOUCH are independently adjustable, the numerical displays on stopper adjustments are showing the position in mm (metric).

Lift down the support plates

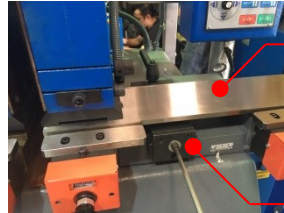

ADJUSTMENT TOOL
(Adjustment of Stoppers)

SUPPORT PLATE

Dismantle the pad plates



Turn to left on all stopper adjustments, make more space

Put into jaws the large and long Alignment Gauge

Position the Alignment Gauge with touch on back edge, on both jaw blocks should be contact

Clamp with one jaw (left or right no different), please use 100 BAR clamping pressure only.



STOPPER-EDGE (4X)

Disengage the all stopper-edges

Move the CSL (center stopper left) stopper very close to stop bar by turning on the hand wheel

Fix the stopper-edge with straight contact to stop-bar

Calibrate the numeric display to 10 mm

Disengage the little screw and turn The ring together with little screw by using the Allen key

Make sure, the hand wheel is not turning!

Repeat for all other stoppers the procedure

After this procedure, all stoppers should have a straight line when same number is visible at the numeric displays. The Number is in mm (metric) and is showing the space between jaw and stopper, also usefully as the Tooth Gullet size.

Please check and service the Stoppers frequently!

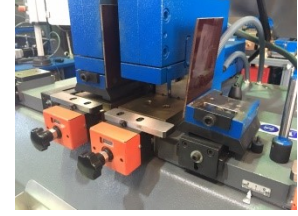
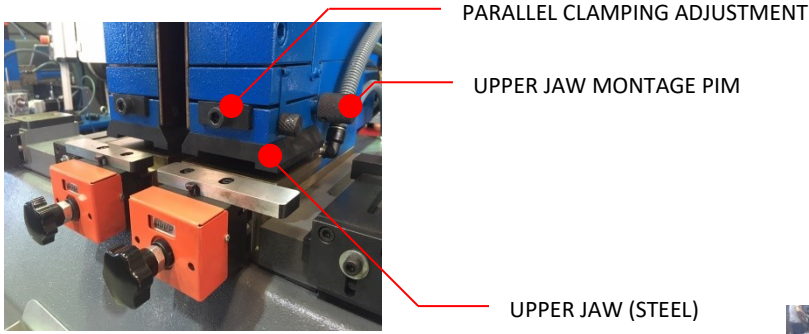

SERVICING THE JAWS (PLEASE SERVICE THE JAWS FREQUENTLY)

pull out the "Upper Jaw retaining pin"
 move front the upper jaw block

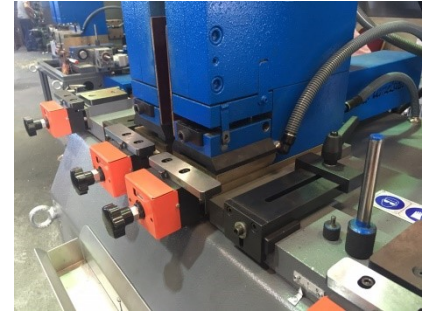
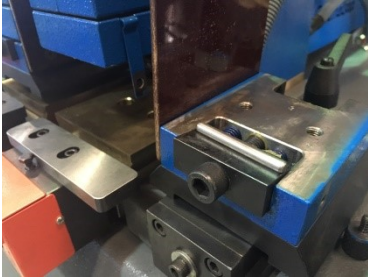
Aglet for Upper Jaw justify

BE CAREFULLY !

There is a PIN with special form (upper jaw leveler pim) make sure you don't lose it

Positioning of PIN



Round to top
 flat to down
 usually they are
 fixed with grease

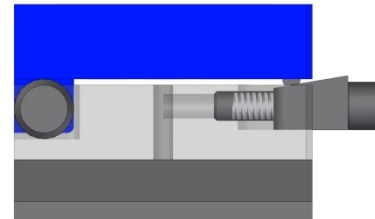
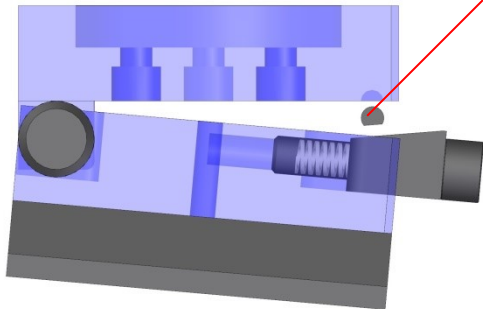

Turn upside down the upper jaw block

Unscrew the upper clamping jaw

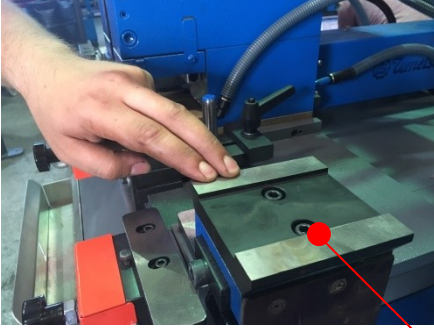

UPPER JAW ASSEMBLY SCREWS

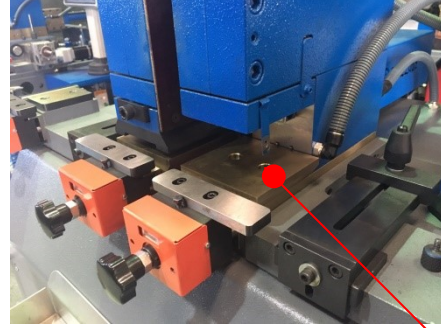

LOWER JAW ASSEMBLY SCREWS

The Jaws have to be clean and free from grease

The surface has to be straight

The edges on the welding side have to be clean and straight without any cracks

CLAMPING JAW GRINDING INSTRUCTIONS

The lower jaws (Bronze) -just to grind on top surface until any crack on weld edge is out
-Both lower jaws have to be same thickness; it's recommended to grind it together as a pair

The upper jaws (Steel) -just to grind on bottom surface until any crack on weld edge is out
-Both upper jaws should have the same thickness

We recommend to grind the surface of jaws frequently, that has the advantage of

- Better power connectivity
- Straight surface
- Higher weld precision

As earlier you take it out to grind, as less material have to be grinded, the life of jaws will increase.

INSTALLATION OF CLAMPING JAWS

Please make sure that the touch points between Jaws and Jaw-blocks are clean and free from grease.

When you place the Jaw to position it, check if all surface has contact, very clean between. Do not create the contact by tighten the screws.

When fixing the screws, not too tight please!

CLAMPING DEVICE

The clamping devices are Hydro-Pneumatic system to clamp Metal Band or Band Saw Blade for butt-welding procedure.

The Clamping power is up to 500 Bar, so keep your hand far away from the clamping jaws when using it.

The Oil-Level has to be controlled frequently by viewing the size of the space between Jaw

Block and Piston.

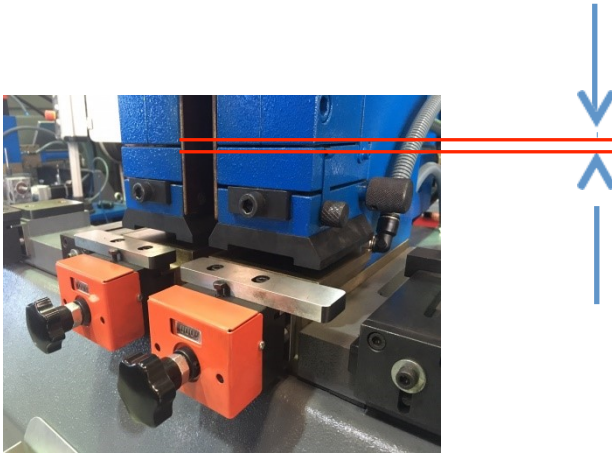

Piston Oil Level Check

Check the space showed on picture is the space is:

2mm	=	OK
0-1 mm	=	too low level of oil
3mm or more	=	too much oil

Use of clamping devices

Use the pedals to clamp and unclamp the clamping devices. Keep your hand far away from the clamping devices when operating on the pedals!

You have the possibility to select between single or double action of pedals, that means single for each pedal, one clamping vice or double for one push of one pedal to close or open both vices together.



MANOMETERS

Each gauge is showing the Pressure of each Piston. (Left Jaw or Right Jaw)

The Pressure to read or to adjust is depending the position of clamping devices.

Select first the Position of Clamping Device!

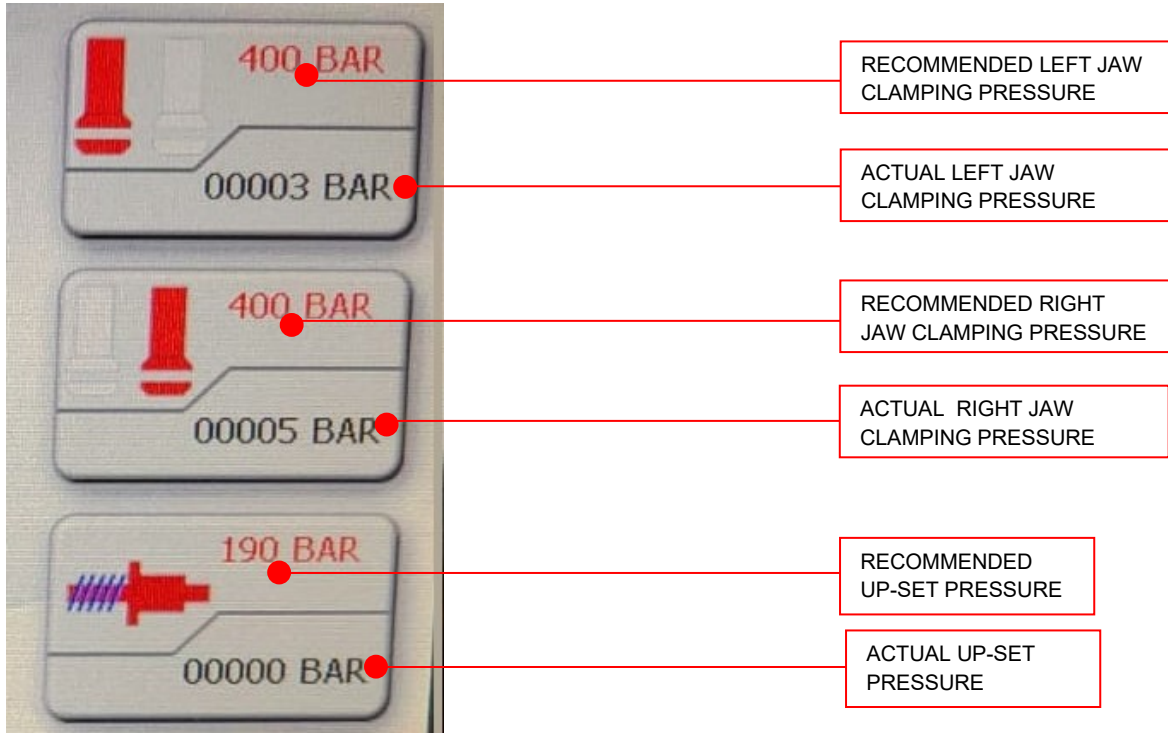

CLAMPING PRESSURE ADJUSTMENT VALVE

The Clamping Pressure for welding and annealing must be high. Please use the Parameter Chart
The high Clamping for Welding has different advantages,

- ones for absorbing the Upset-move
- second to straighten the X-Camber on large widths for high weld precision

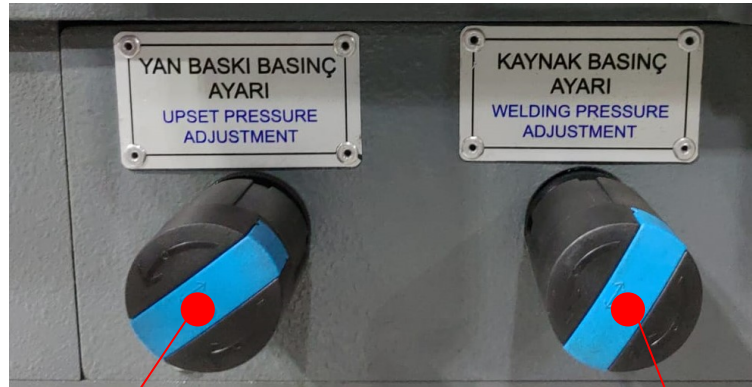

UP-SET PRESSURE
ADJUSTMENT
REGULATOR

CLAMPING PRESSURE
ADJUSTMENT
REGULATOR

UPSET PRESSURE

Temelsan Machines are working with 2 step procedure of Upset Pressures.

The 1st step is the light pressure during the current flue time and the 2nd pressure is the high pressure immediately when the complete metal is melted and current is switched off.

Current Switch Off position is adjustable on the screen, called "Welding Stop Point".

The 1st step Upset Pressure is just controllable and adjustable only by maintenance.

To check the 1st step upset pressure is quid easy, just take the Clamping Jaws in Annealing Ready position, clamp the jaws (without Metal Band / Band Saw Blade between), push start button and quickly after the Stop button.

The Pressure will be visible on the Upset Manometer. 5-20 Bar Pressure is OK, "0" (Zero) Bar means, the maintenance should add Oil value into Upset-Piston, if the pressure is higher then 30 Bar, the maintenance should reduce oil value into Upset-Piston.

The Upset Pressure Step 2 can be adjusted only when Clamping Jaws are in Welding Ready Position! Also you can control it on Welding Screen by the using Up-Side Pressure Button

When ones the Welding Ready position is reached by the Clamping Jaws, it's anytime possible to push the Green Button, called Upset Pressure-Button.

The Manometer will show the adjusted pressure.

Take the needed Upset Pressure information from your Welding Chart and adjust by turning the Upset Pressure Valve.

JAW LEVEL CALIBRATION (CLAMPING JAW ANNEALING PRESSURE POINT)

There is on both Clamping Jaw Blocks a Jaw Level adjustment Screws they makes the adjustment very easy.

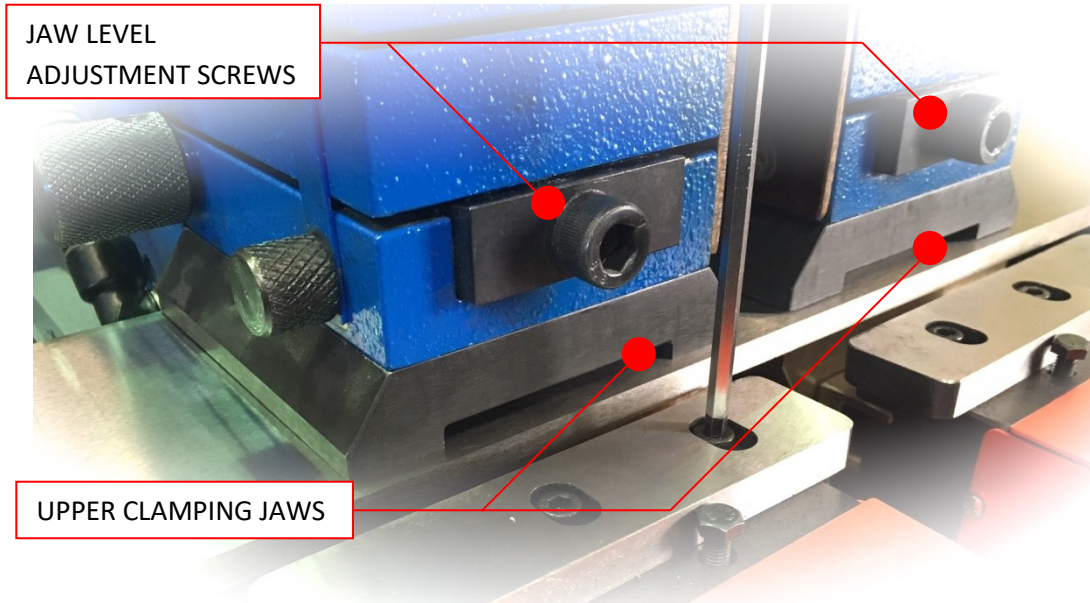

With changing of Annealing Press Point we are able to clamp properly all different width of Metal-Band





LOWER JAW

Band Clamping Pressure Point

Where the pressure is higher, there is more electric connectivity, so the heat we want to create for proper annealing is there as highest. The goal is to create similar heat on all width of Metal-Band.

The jaw blocks are designed to be able to clamp different widths of Metal-Band or Band Saw Blade

Metal-Band Large Width Positioning

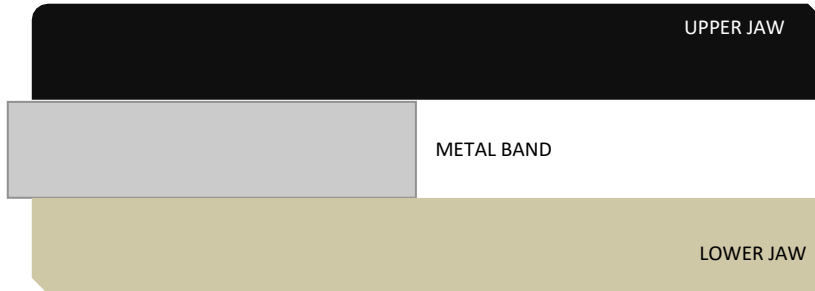

Metal-Band Small Width Positioning

IMPORTANT TO KNOW!

The Clamping Pressure of the upper jaws has to be adjusted correctly in advance, in general is to know, as larger the band width as more clamping pressure can be used. There is recommended to memory the clamping pressures for each band size on a Parameter Chart.

What's happen when too high clamping pressure is adjusted.

In this case it's almost not possible to make a Jaw Level Calibration.

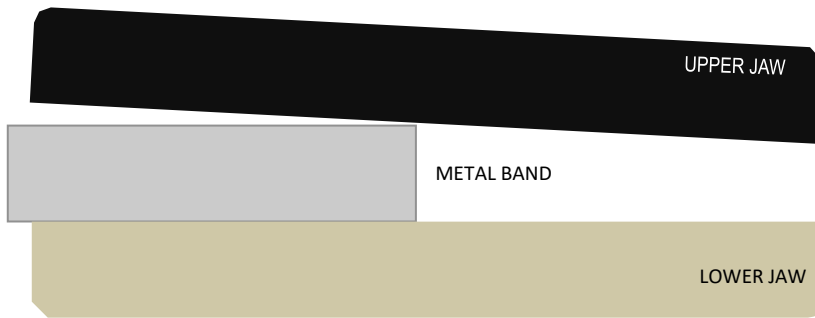

Band Annealing Pressure Point (Jaw Level Calibration)

Clamping Pressure should be correct for each selected band-width.

When Clamping Jaws are on annealing position and using the annealing procedure the heat will show where the Annealing Press Point are.

Where the pressure is, there is the electric connectivity higher, so the heat we want to create for proper annealing is there as highest. The goal is to create similar heat on all width of Metal-Band at the same time

like on picture # 1.

Picture # 1



PRESS POINT

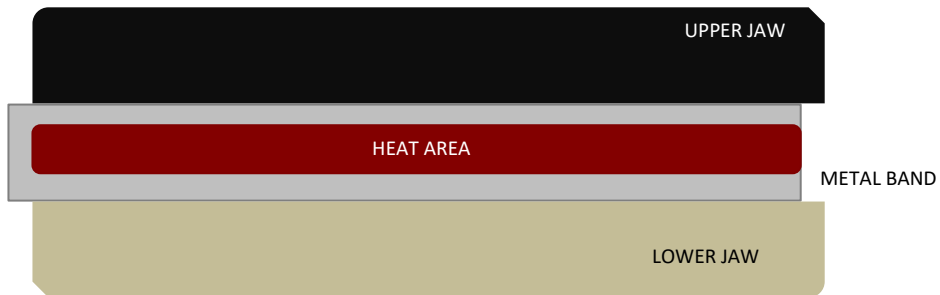

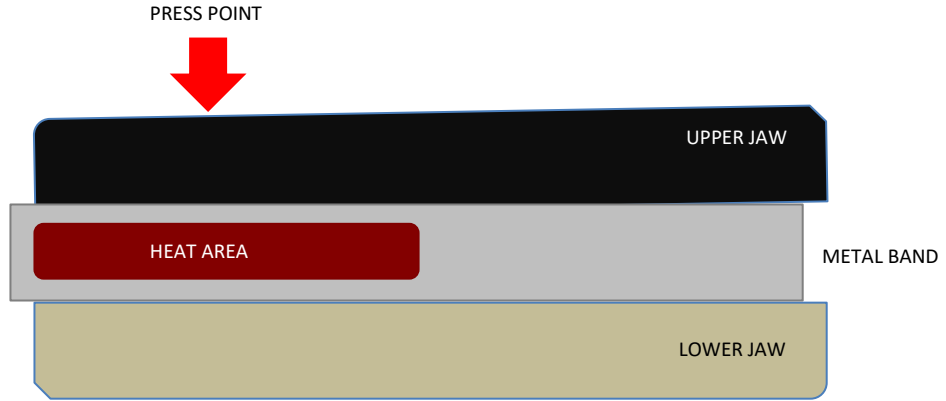
Picture # 2 **Improper Adjustment**

Band Annealing Pressure Point (Jaw Level Calibration)

To keep similar Annealing clamping Press Point on both Clamping Jaws it's always recommended independently how tight the screws are turn able to work with an Allen key and using it as a dial like on a watch or dial indicator, in 5 minutes steps or 10 degree.

IMPORTANT ALWAYS BOTH SCREWS ARE TO TURN AND ALWAYS SAME WAY THE SAME QUANTITY!

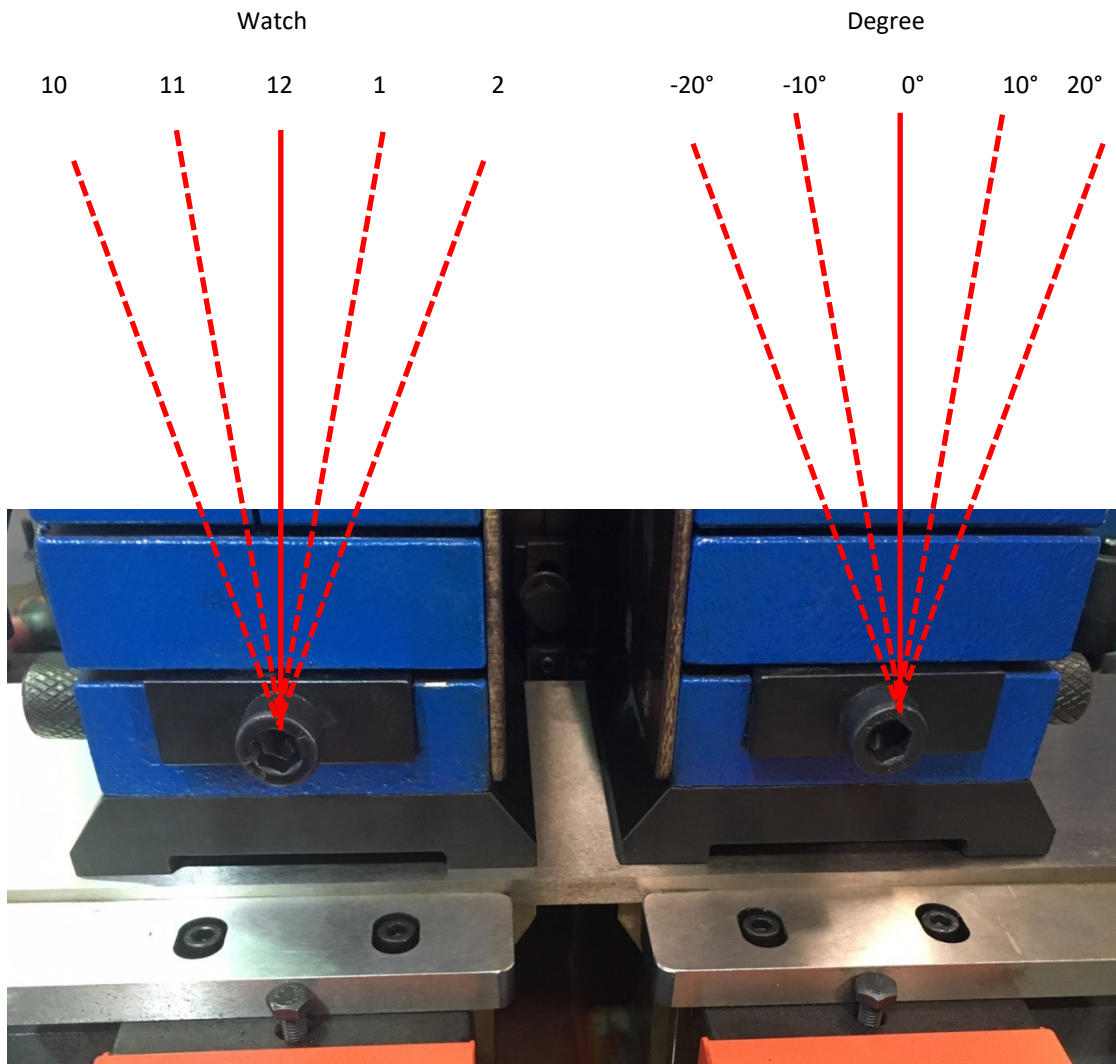

JAW BLOCK LEVEL ADJUSTMENT

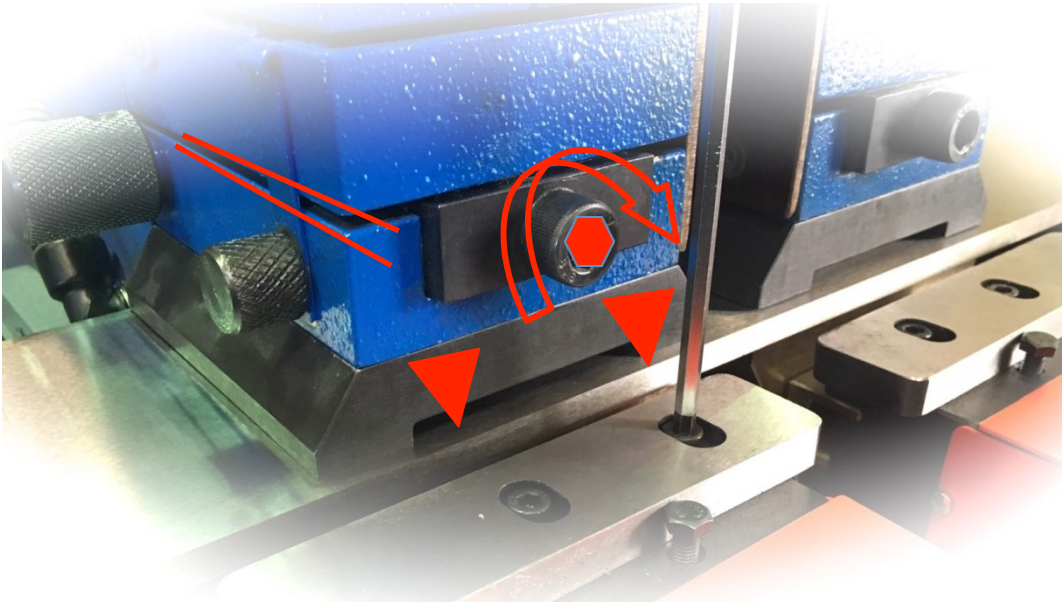

Turn the Jaw Level Adjustment Screw clock wise (to the right side) the Upper Jaw will create more clamping pressure on the front side. Turn the Jaw Level Adjustment Screw opposite direction (to the left side) the back clamping pressure between jaws will increase.

CLAMPING JAW CALIBRATION BY CARBON PAPER

The calibration by Carbon paper brings more precision and is to use frequently after several position changings but for sure after Jaw replacement.

1. Position the Jaw Blocks to Annealing Ready Position
2. Adjust the Clamping Pressure to 300 Bar
3. Place the carbon paper package between jaws
4. Clamp both Jaws and wait few seconds
5. Take out the carbon paper package and study the picture
6. Adjust the jaws until you gain similar clamping picture over all width of both jaws
7. Place an 27mm Band, run an Annealing and watch where the heat starts, back edge or teeth edge side, depends adjust both Jaws to center the heat start to middle of Band.

Carbon Paper Sandwich

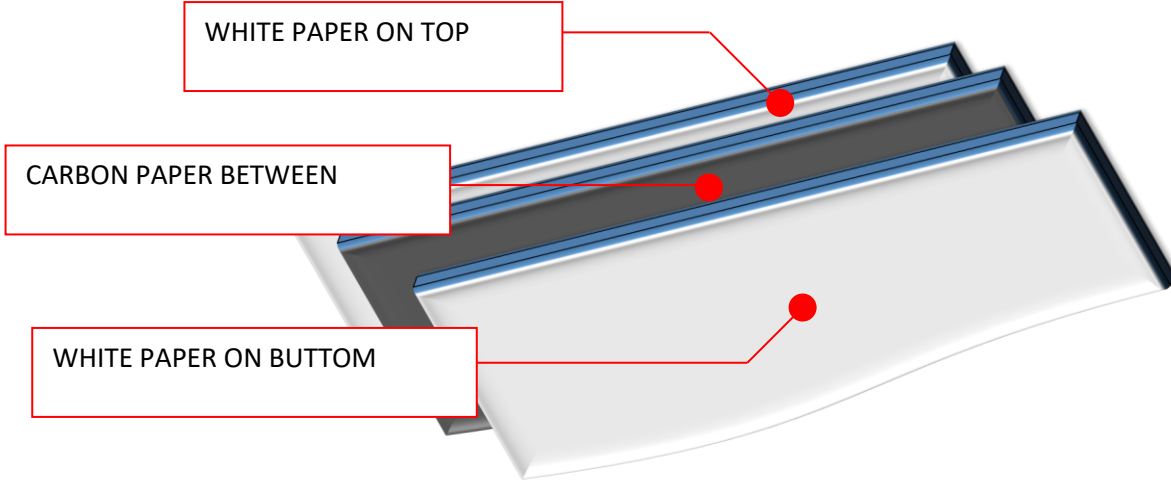

The Carbon Paper Print is showing similar print picture on both clamping jaws as an perfect similar adjustment.



Left and right Jaw are not correct adjusted

Left Jaw too much back pressure or the right jaw too much front pressure, depends the band width

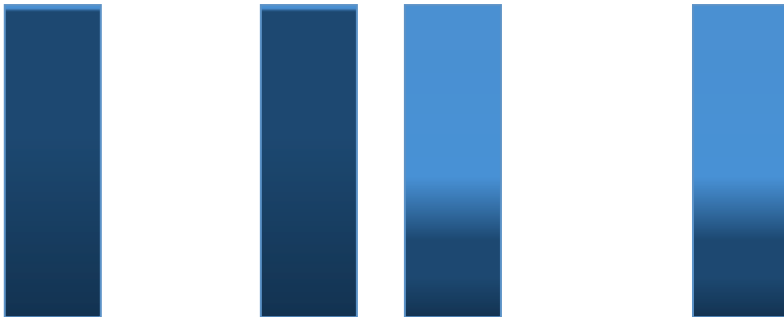

Left or right Jaw is not correct adjusted

Cross clamping; this type of adjustment can show when annealing an perfect center adjustment but the weld is not precise. Breakage it's possible.

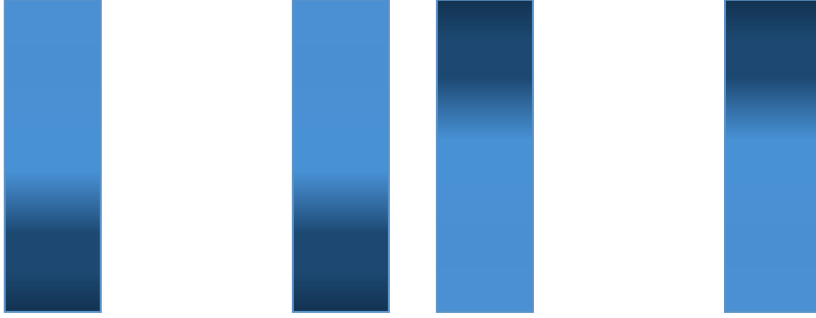

The Jaws have to be re-grinded with a high precision surface grind, have to be checked about deformation and correct fixed

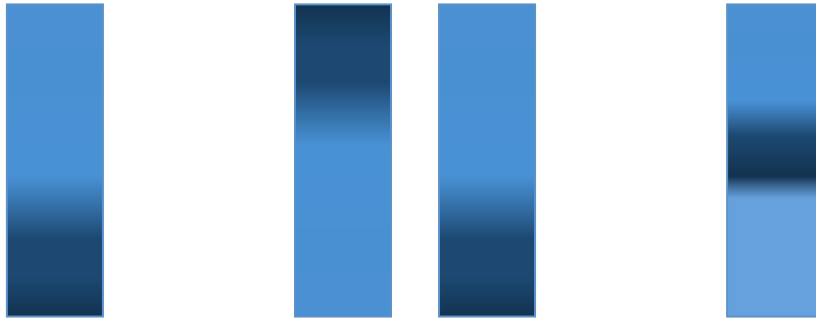

PEDAL USE TYPE

The pedals are made for to clamp or unclamp the Jaws.
For each Jaw is one Pedal

Save time if you are well trained by placing the band to weld.
Select one the screen the Pedal Selection **DOUBLE**.

SCREEN MENU 2

PEDAL SELECTION	
SINGLE	for single usage
DOUBLE	for double usage



OPERATING TYPE

The Butt Welding Machine KN 100 HBA TOUCH is designed to run with conventional cycles, which is called MANUEL, and modern cycles AUTOMATIC.

- Manuel>** Machine stop to work after weld only is made,
operator has to replace the Band for annealing procedure
- Automatic>** Machine is welding, replacing position and Annealing by self,
even the air- cleaning they do by self

More details at following pages

MANUEL WELDING PROCEDURE

Welding

1. Clamp the jaws with band to weld in
2. Push START button to weld, spark flow, weld in process
3. Push the pedals; jaws are opening and moving to Annealing Position by self Take out the Band and clean Band and Jaws by Air, free from dust

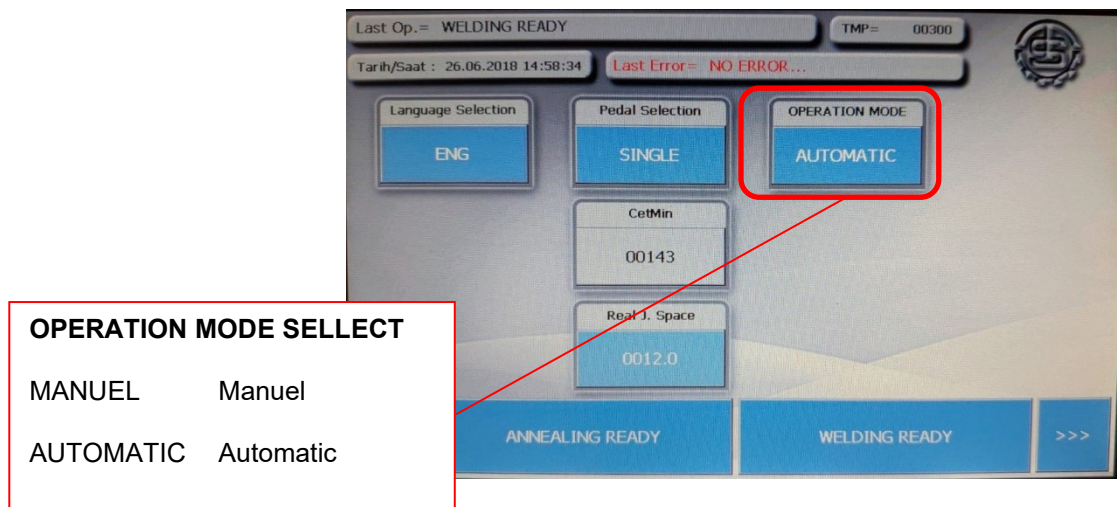

Automatic Annealing Type (The Annealing procedure will start as soon you push START button)

4. Clamp the jaws with band to Anneal in, make sure the pyrometer laser is correct positioned
5. Push START button to Anneal, the Weld-Area gets hot about 600°C,
The annealing procedure (Swing Annealing lowest Temp. highest Temp. medium Temp.)
 - a) Pyrometer PICKSET Heat Up process
 - b) Heating the first Temperature and keeping Temperature during Time 1
 - c) Heating the second temperature and keeping Temperature during Time2
 - d) Heating the third temperature and keeping Temperature during Time 3The annealing procedure stops self when the pre-adjusted time is done
6. Push the one pedal; both jaws are opening and moving to Welding ready Position by self
The Weld and Annealing is done, please let cool down the weld by self before grind the weld

A Automatic Welding procedure includes the Annealing Procedure and Air Blow Cleaning.

Make sure the Annealing Type and Welding Type are as automatic selected into operator screens.

AUTOMATIC WELDING PROCEDURE

Welding

7. Clamp the jaws with band to weld in
8. Push START button to weld, spark flow, weld in process
9. Right jaw open by self and move to right direction, automatic air blow cleaning during moving, when position reached its will close by self.
10. Left jaw open by self, the right jaw pulls the band to center the weld between the jaws, jaws are closing by self.
11. Annealing Starts by self the procedure
The annealing procedure (Swing Annealing)
 - i. Pyrometer PICKSET Heat Up process
 - ii. Heating the first temperature and keeping temperature during TIME 1
 - iii. Heating the second temperature and keeping temperature during TIME 2
 - iv. Heating the third temperature and keeping temperature during TIME 3The annealing procedure stops by self when the pre-adjusted time is done.
12. Both jaws are opening by self and moving to Welding Ready Position by self, air blow cleaning during this procedure automatically.

(Use glasses to protect your eyes and cover yourself from sparks)

The Weld and Annealing is done. Please let cool down the weld by itself before grind it

Any time can be run an Annealing procedure, just position the Jaws in Annealing ready Position, clamp the band and push START. If AUTOMATIC is selected; the swing annealing is active, If MANUEL is selected just one Time and one Temperature annealing is active We call them; timer annealing.

When the Annealing Type Manuel selected, the machine will run one time and one heat temperature only.

ANNEALING PROCEDURE MANUEL & AUTOMATIC MODUS

The machine types KN...HBA are serially using an Pyrometer Heat Measuring System, this system allows to control the heat for Annealing. The Pyrometer Heat Measuring System is to activate before it could use. The activation address is the second operator menu under **ANNEALING TYPE**.

Temelsan Machines recommending in respect to an free adjustment of Temperatures and Times possibilities by User to run the Swing Heat type of Annealing (AUTOMATIC ANNEALING).

Automatic Annealing Type

1. Position the Jaws to ANNEALING READY, clean it by air blowing
2. Position the Band properly, (see pic for band positioning)
3. Clamp the jaws; make sure the pyrometer laser is correct positioned
4. Push START button to Anneal, the Weld-Area gets hot about 600°C, dark red, (think; jaw level) The annealing procedure (Swing Annealing)
 1. Pyrometer PickSet Heat Up Time / process
 2. Heating the first Temperature and keeping Temperature during Time 1
 3. Heating the second temperature and keeping Temperature during Time 2
 4. Heating the third temperature and keeping Temperature during Time 3

The annealing procedure stops self when the pre-adjusted time is done

5. Push one pedal, both jaws are opening and moving to Welding Ready Position.

Anytime possible to Stop the procedure but a new start has to be repositioned the jaw to Annealing Ready Position.

Band Positioning (adjust the Stoppers to correct position)

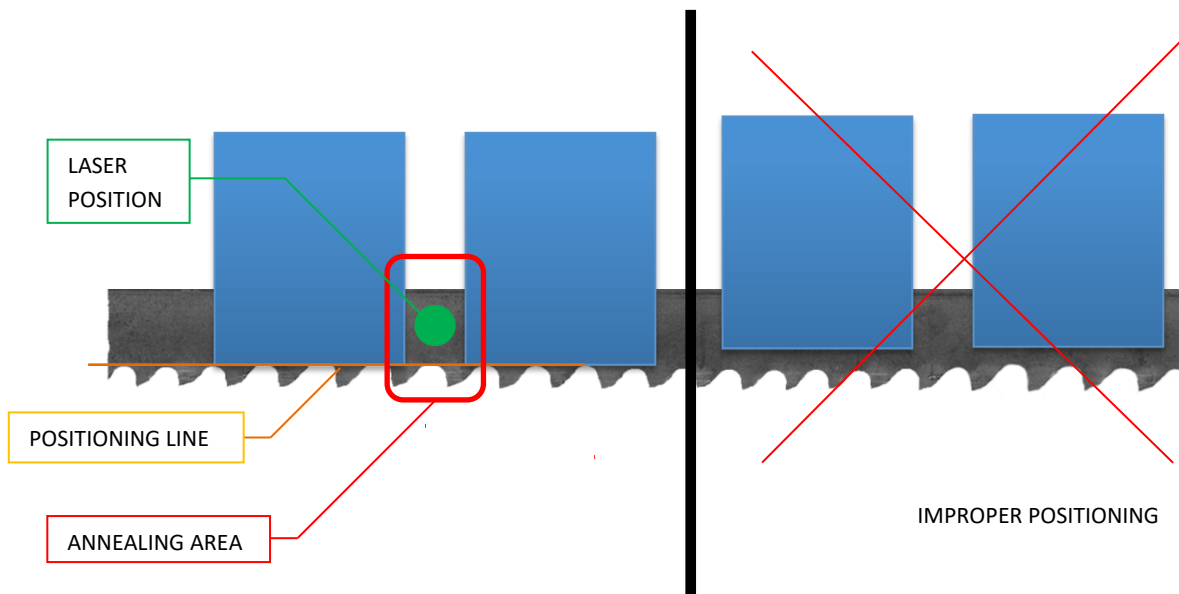

PYROMETER POSITIONING

The Pyrometer is a high efficient device to control the heat temperature. It limits the machine to heat up over the pre-adjusted Annealing Temperature.

The Pyrometer has a Laser Light to position the Pyrometer Measurement Point.

The Measurement point has average 5 mm Diameter but the Measurement Area into center of the Red Point is 4mm. To adjust the measuring point is manually, easy to unlock the holder and turn and move sideward the Pyrometer-Box.

Needs for proper measurement:

1. Perfect Jaw leveling (the heat should start from the middle of the band width)
2. The weld Burr should be exactly centered between the Jaws
3. Pyrometer Laser Point must be adjusted center between jaws exactly over the Burr and center to the bandwidth.

The **CENTER** function at operator menu screen is to calibrate the center the Weld automatically. Please view the next page for it.

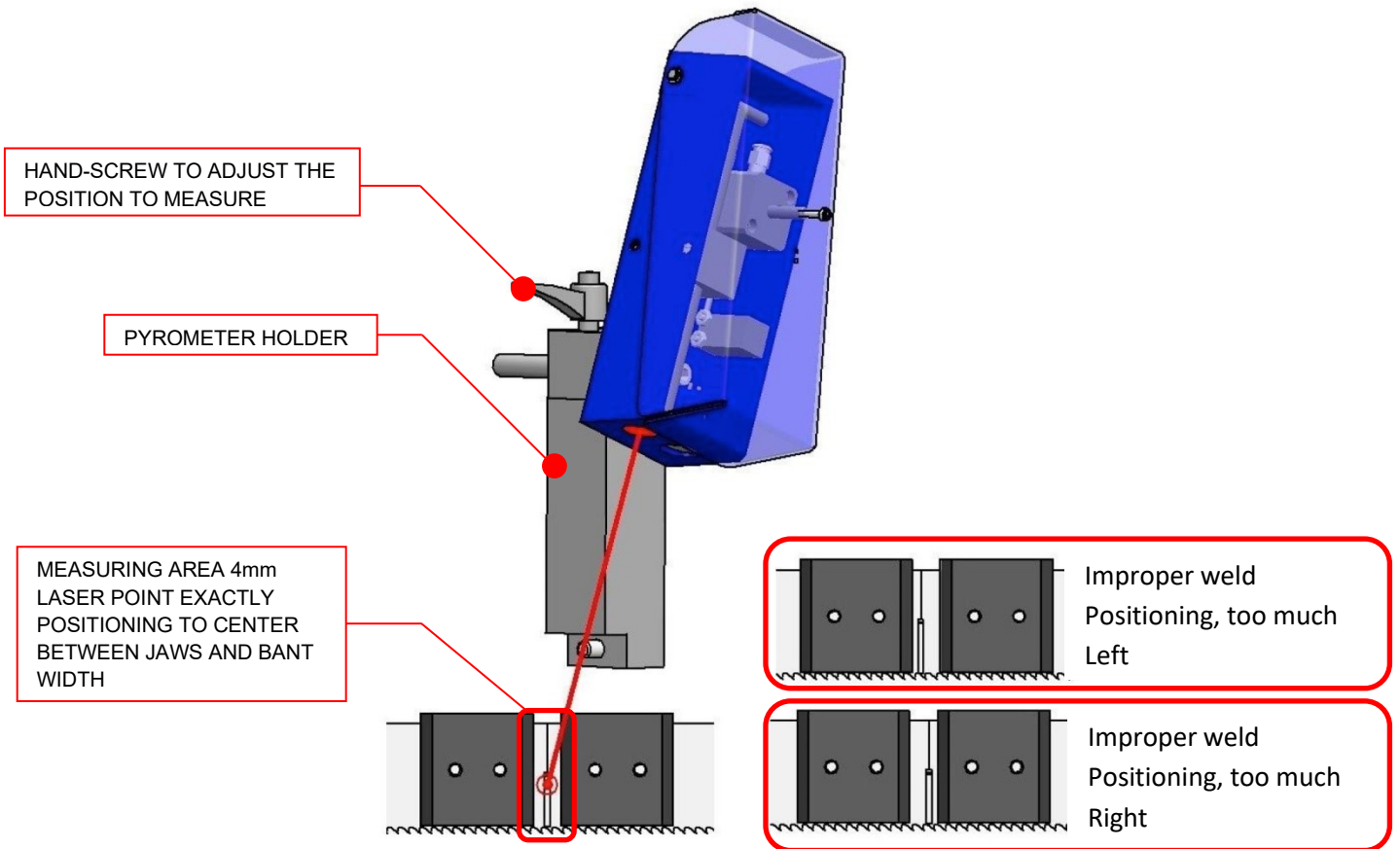

CENTER

Function at operator menu screen (To calibrate the weld center between jaws)

The Center function is a tool to calibrate the automatic move of band when jaws are changing the clamping position from welding position to annealing position. This process is only during automatic weld procedure active.

To make adjustments on LEFT JAW POINT only when following points are proper used

1. The operation type has to be activated as Automatic (Weld after Anneal automatically)
2. The Up-Side Pressure should be proper adjusted and should work with constant Air supply
3. The Weld Burr should have the right form and proper view
4. Weld Spacing should be adjusted correctly
5. Changes on Welding Stop Point influence the Weld Centering Automatic too

Centering of Annealing Point (Left Jaw Point)

Automatic clamping vice positioning after Weld to Annealing

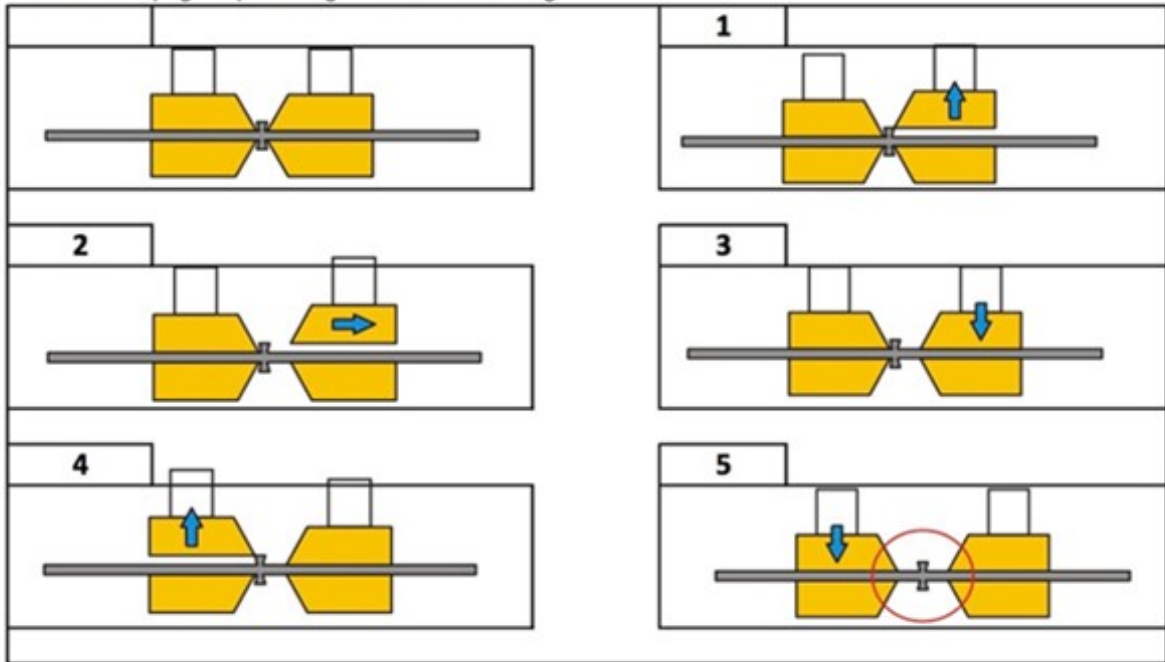

Decrease or Increase the Number at Left Jaw Point, to find on Operator Menu

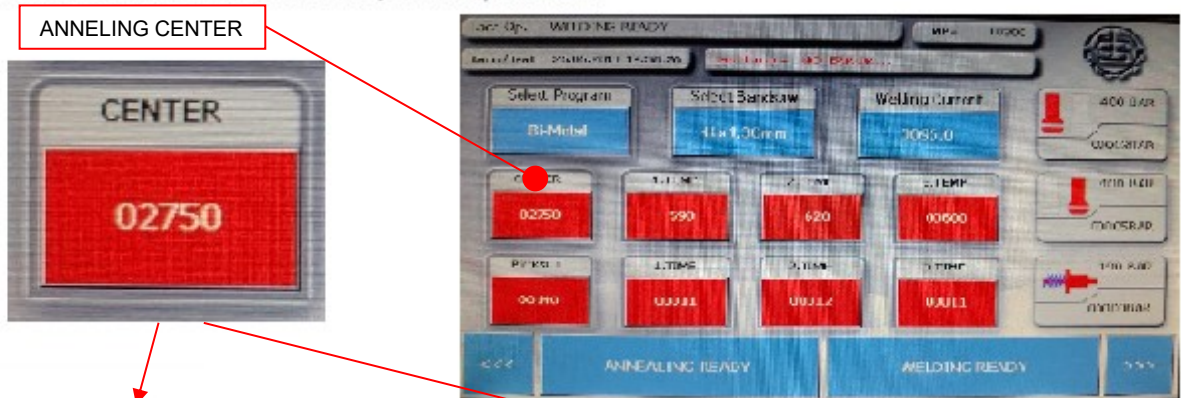

Too much at Right

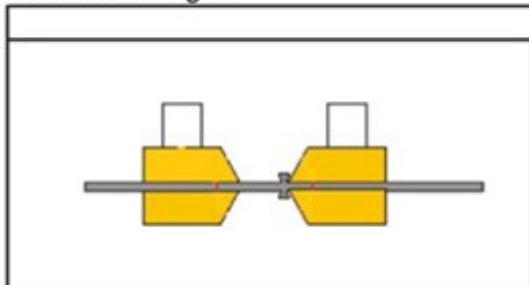

Decrease the Number by 10 or more

Too much at Left

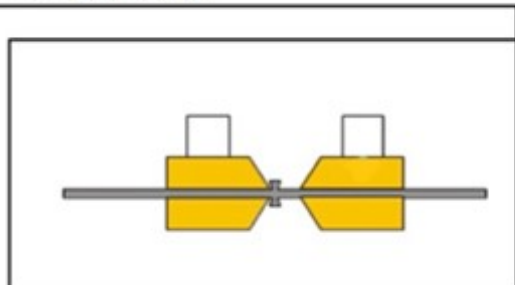

Increase the Number by 10 or more

SUMMARY OF FUNCTIONALITY TYPES

Explanation of used Technical Names

Welding: The Welding means only for creating the putt-weld without any Annealing.

Annealing: It is the procedure after Weld to soften the Burr and Welding Area for making Metal elastic and Grind able. Without Annealing the weld would broken like glass.

Press-Air-Blow Cleaning:

The Press-Air blow is to clean between the jaws when they are opened to replace positioning. In Automatic Cycles is blowing by self, by Semi-Automatic cycles should be done by operator.

Automatic; Welding – Annealing – Air Blow Cleaning

Adjustments on Screen; OPERATION MODE > AUTOMATIC
ANNEALING TYPE > AUTOMATIC

Manuel;

Welding

Stop by Self when welding only is done, Jaws keeps clamped. Annealing

The Operator has to unclamp the jaws, automatically the jaws are moving to Annealing Position, the operator has to clean by press-air between the jaws, has to place the blade well centered into jaws, has to clamp the jaws and start the Annealing Procedure.

Adjustments on Screen; OPERATION MODE > MANUEL
ANNEALING TYPE > AUTOMATIC

Fully Automatic without Annealing Swing Procedure;

Welding – Annealing – Air Blow Cleaning

The all procedure will run like the fully Automatic procedure, but for heat control of annealing will be used the manual pre-adjusted heat time and heat power percentage.

This procedure needs an carefully special view, its just recommended when the Heat Measurement (Pyrometer) makes troubles.

Adjustments on Screen; OPERATION MODE > AUTOMATIC
ANNEALING TYPE > MANUEL

WELDING STOP POINT

The welding STOP point is that position when the power for weld flash must be switched OFF. This position was many years to adjust on a manual wheel on left hand side of the Butt-Welding machines for Band Saw Blades. Today we adjust it with much more precision electronically. The advantage of electronically STOP point positioning, is that for each Band size the position is saved and independent programmable.

The welding STOP point is dependent by Jaw-Weld Spacing (pre-adjustment), by Upset-Pressure level and by Weld Power. If one of those points will be different or has an inconsistent flow, than it could be a need to readjust the Welding STOP point.

The consistent flow of POWER, the consistent and fast preload of Press-Air, the manual adjusted Jaw- spacing are very important points and needs special view.

Example:

Band	Power	Spacing	Upset-Pressure	Stop-Point
100mm	950	16 mm	450 Bar	1420
100mm	950	16 mm	400 Bar	1445

1. We recommend for an new adjustment, to reduce the Stop-Point number extremely like to 1400 for to weld for example an 100mm Band with 950 Power, 16mm Weld Spacing, 400 Bar Upset-Pressure.

2. Make a Weld, make an Annealing with well-centered weld between jaws and well-positioned Pyrometer, view the Burr and test the weld after carefully grinding on the Bending-Tester of Temelsan.

3. If the Burr is too small, increase the Welding Stop-Point by 3 Numbers and run the same test procedure. Increase the Stop-Point number by number until you find the best weld, unbreakable weld.

Few well welded Burr Pictures (different Band widths)

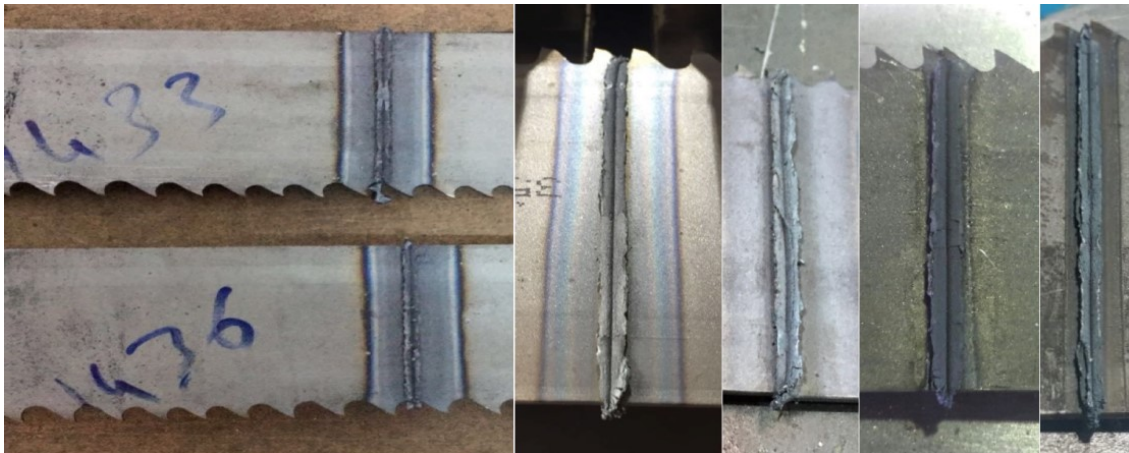

PYROMETER PICKSET

Fast Heat-Up until the First Temperature Set is reached.

The program is starting the welding machine for Annealing procedure by starting to heat-up the Band between the Jaws. Fast Heat-up until the Temperature you want is saving time.

The Pyrometer is used in this case as a switch, which stop the heat-up procedure when it's reached the adjusted Temperature. Several times the program is starting this heat-up procedure until the pre-adjusted time is done.

On Temelsan Machines is the heat-up time adjustable on the Field **PICKSET** on second screen

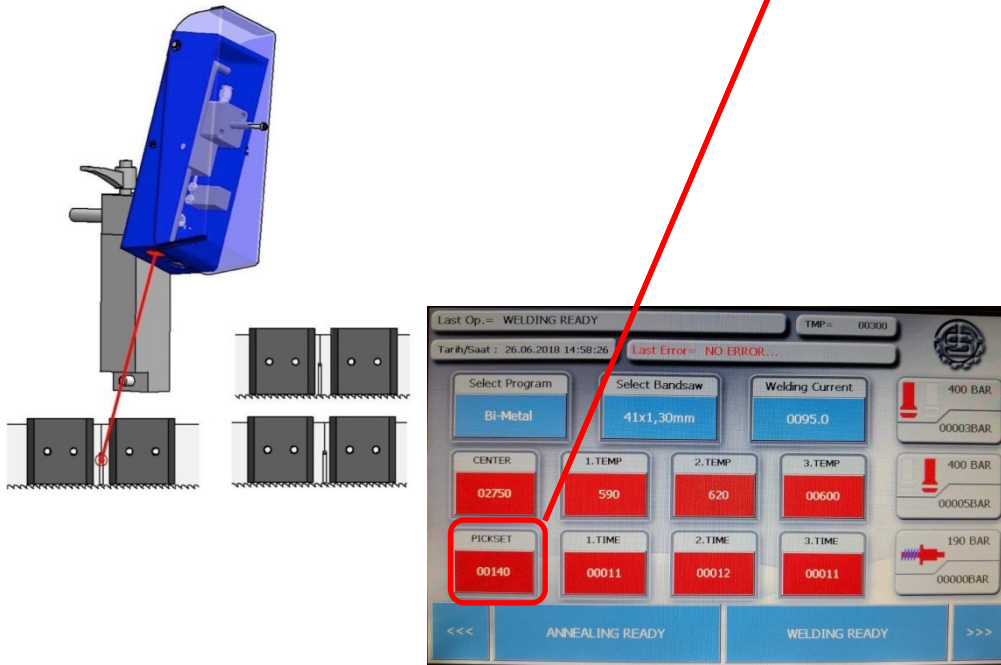

As higher the number as faster the heat is increasing up, but be carefully, if it's increasing to fast the Temperature the Band could be melt before Pyrometer has measured the Temperature.

The Pyrometer is measuring frequently the Temperature but not constantly.

Depending the Band width and band thickness has to be adjusted the PICKSET
For each band width and program is an different PICKSET

The PICKSET is automatically also used for De-Burring system.
The PICKSET is only active when Annealing Type is Automatic selected

WELDING SPEED

The Welding Speed is the controlled speed during flash
The Flash has to be constant with a constant noise

The consistent flow of power and they volume and the connectivity of jaws and Band are important.

Too fast welding speed can be responsible for unfinished flash weld and also for deformation of weld area. Too slow welding speed can be responsible for melting out the all metal and so the breakage of weld

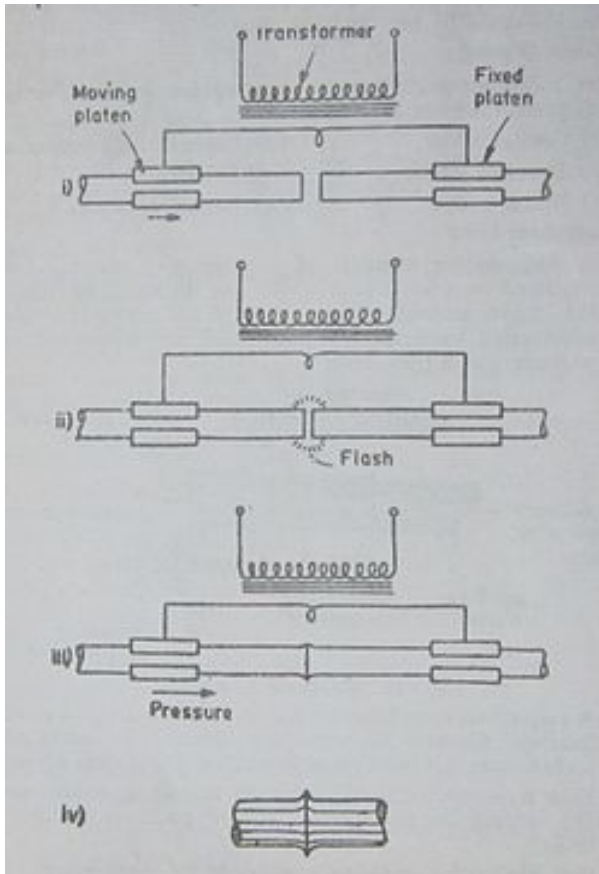

WELDING SCREEN

The Welding Speed has to be adjusted for each Band Size

QUICK MANUAL CHART

Follow the steps and run a successfully weld!

1. Switch ON the **“Main Power Switch”** and push the **“Blue Start Button”**
2. Check the **“Air Pressure Regulator”** 9,5Bar
3. Push the **“Welding Ready Button”** the LED light should go ON
4. Select the **Program #** at Welding screen
5. Select the **“Band Width”** at Welding screen
6. Adjust the **“Welding Space”** by hand wheel
7. Adjust the Weld **“Clamping Pressure”** Regulator
8. Adjust the **“Up-Side Pressure”** Regulator
9. Push the **“Annealing Ready Button”** the Jaws will move
10. Adjust the **“Stoppers”** for right tooth gullet deepness
11. Adjust the **“Outside Stoppers”** (outside stoppers 2x $\approx +0,1\text{mm}$)
12. Adjust the **“Pyrometer Position”** manually by hand
13. Run the **“Jaw Level Calibration”** read manual
14. Push the **“Welding ReadyButton”**
15. Position a band, Clamp the Jaws
16. Let cool down your weld after machine has finisher the procedure
17. Measure the high/low with Temelsan **Camber measurement tool**
18. Grind carefully both side of weld
19. Grind carefully the Gullet
20. Grind carefully the back edge of band
21. Test the Weld by **Bending Tester** from Temelsan
22. If Weld quality has passed the Tests, Start your manufacturing

POWER AND PRESS-AIR (Machine Power and Air supply check chart)

KN-100-HBA-TOUCH model

Power Supply Check

100mm Band Saw Blade
99,9% Power

Example Values

15mm space
500 Bar Clamping
Up-side pressure 350 Bar
Stop point start by 4000
Welding speed 120-140

Weld and view the spark production:

if spark production is inconsistent, reduce the Welding Speed to 120,

-if 3 welds are not equal spark production the Power supply is not enough, change the wire sizes to thicker wires.

-if all 3 welds are producing consistent sparks the Power is enough and can be approved.

Air Supply Check

Main Air Supply minimum 7 maximum 8 Bar

The compressor should be adjusted as starting to fill the air by 9 Bar and stop to fill by 11 Bar if Clamping Pressure does not reach the 500 Bar, the main air pressure is too low Never adjust the main Air pressure over 10 Bar. Factory adjustment is 9,5 Bar The Tube size for Air Pressure supply is minimum 12 mm.

Machine can weld the smaller band widths by lower Air pressure but the wider band widths could be not welded well. In fact you limit your machine if you use low air pressure supply.

If Power supply and Air Pressure supply is approved, could be started with welding parameter adjustments with smallest bandwidth as first.

Use the Setup instructions and recommended welding chart Table from Temelsan.

LIST OF ALARMS AND INFORMATIONS

The Machine can create Alarms by giving hearable ton and visible Text. Any Alarm has to reset by pushing STOP when the issue is solved.

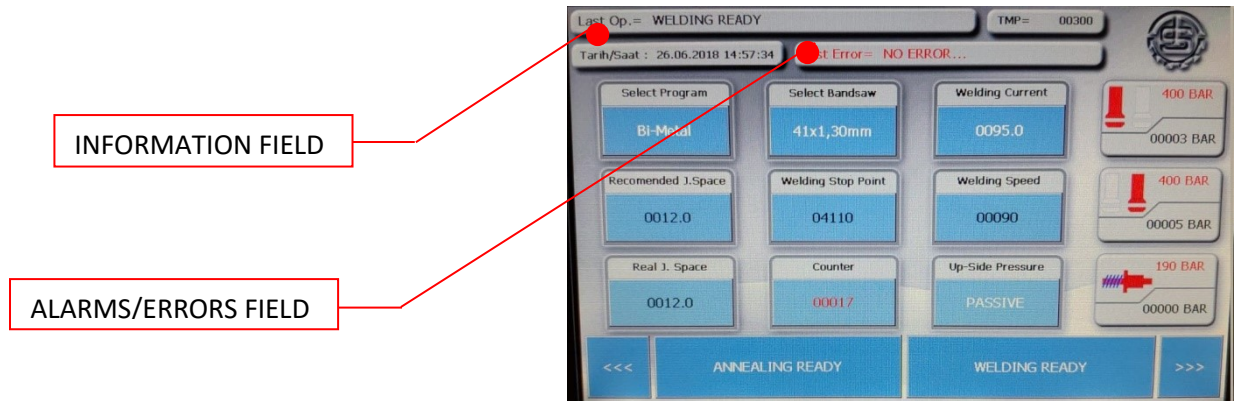

INFORMATION Field

WELDING READY
ANNEALING READY

LEFT JAW CLAMPED
RIGHT JAW CLAMPED
LEFT JAW UNCLAMPED
RIGHT JAW UNCLAMPED
JAWS ARE CLAMPED
JAWS ARE UNCLAMPED

T :WELDING READY P.
T :WELDING START P.
T :WELDING STOP P.
T :UP-SIDE PRES. P.
T :RIGHT OPERATION P.
T :LEFT OPERATION P.
T :ANNEALING READY P.
T :ANNEALING START P.

DE-BURRING FRONT...
DE-BURRING BACK...

COOLING TIME...
ANNEALING TIME...

JAWS CAN BE UNCLAMPED

WELDING START
WELDING STOP
CANCEL OPERATION
UNKNOWN OPERATION NUMBER

ALARM / ERROR field

NO ERROR...

DE-BURR. ON WRONG POSITION

AIR PRESSURE IS LESS

CLAMP THE JAWS

NO PALS...

UNCLAMP THE JAWS

PYROMETER NOT PROTECTED

JAW SPACE ERROR .PLEASE ADJUST.

ELECTRICAL CURR. IS HIGH

COMMUNICATION ERROR

PARAMETER CHART AND MEMORY

The machine memory any electronically used parameter; the memory is active and is saving immediately when entering any data. Like any other electronically data system, it's possible to loos the data.

A Parameter table memorizes the Clamping Pressures and mechanically adjusted positions and equipment's. The table is supplied as hardcopy and also as digital Microsoft Excel Table.

We recommend to memory at this chart any changes you made by your adjustments. To





Any Machine is an fully filled Parameter Table as an Hardcopy supplied.

The Parameters are no guaranty for perfect Weld, the Parameter adjustment are made under an specific power and air-pressure supply which can be in any country and/or region differently.

Corrections are possible. We recommend the Temelsan Service to help you for proper adjustment.

Page 1

The numbers are remembering the steps to follow to adjust your welding machine quickly to use. The electronically memorized figures are just to control, all other positions like 7-9 and 11 have to be adjusted for band size any time.

1 Press-Air  at back of Machine		2 Main Power Switch  at front of Power Box		3 Screen ON Switch  right over main power switch		4 / 10 Welding / Annealing Ready Buttons  Operation Keyboard					
5 at Main Keyboard Screen		6 at Main Keyboard Screen		7 adjustments at Welding Ready Vice position		8 adjustments at Welding Ready Vice position		9 adjustments at Welding Ready Vice position		11 at Annealing Ready position	
Band size	Program selection	Band size selection	Current Power	Clamping jaw spacing	Clamping Pressure for Weld	UP-SET Pressure	Clamping Pressure for Annealing				
mm	#	mm	%	mm	BAR	BAR	BAR				
27x0.90	1	27x0.90									
27x1.10	1	27x1.10									
34x0.90	1	34x0.90									
34x1.10	1	34x1.10									

Page 2 Electronically Data Memory

!	<p>A= If, Annealing-Type MANUAL operation is selcted, than the Automatic Annealing (Swing Annealing) will be switched off. In this case hase to be done the pre-adjustment of one constant heat temperature and the timer. At main screen; the fields MAN-HEATPOW and M-HEAT TIME</p> <p>B= The De-Burring system will stil be activated when Annealing Type has changed to Manual Annealing Type. The Heat-Temperature and the Heat-Time has to be adjusted manually. At the fields BURR TEMP TIME and BURR HEAT-POW</p>											
Selected Band size	At screen 1 (Operator Menu)											
	Automatic Annealing Type (Swing Annealing) You can change any time from Automatic to Manual Annealing. Please read on top the changes.								more Adjustments			
Band size	Annealing Type	1. Temp	Time 1.	2. Temp	Time 1.	3. Temp	Time 1.	Piromet Pid-Set Heat-Up speed	UP-SET SPEED	WELDING STOP PT.	LEFT JAW POINT	DE-BURR TEMP Heat Temperature for Auto Anneal Type
mm	Auto / Man.	°C	sec.	°C	sec.	°C	sec.	Heat-Up performance	Upsetting Speed	Power off point before upsetting	Weld centering for Annealing	°C
27x0.90	Automatic	590	5	630	6	615	5					630
27x1.10	Automatic	590	6	630	7	615	6					630
34x0.90	Automatic	590	7	630	8	615	7					630
34x1.10	Automatic	590	7	630	8	615	7					630
41	Automatic	590	9	630	8	615	9					630

Page 3 Electronically Data and Pre-Functionality adjustments Memory

!	C= The DE-BURRING system is for up to 34mm band width system wise deactivated even at screen shows YES. It is forbidden to use the DE-BURRING system if the welding spacing of jaws are less then 10mm pre-adjusted. If Annealing Automatic switched to Manual, the Heat Temperature and Heat Time has to be pre-adjusted too. D= To change or adjust the position of De-Burring edges, adjust the weld-spacing to 11 or more mm. ATTENTION! Move back the De-Burring arm to back position before switching off the Hydraulic. Use for easy adjustment procedure the TEMELSAN DE-BURR GAUGE.											
	at Operator Screen 2								at Main Screen			
Selected Band size	Change of DE-BURRING edges			Additional Adjustments				Manual Annealing <small>When Annealing Type MAN. selected</small>				
Band size	DE-BUR.-ON/OFF	DE-BUR.-MOVE	HYDRAUL.-ON/OFF	PEDALS SELECT	AUTOM. F./SEM. Machine cyklus	TR-ENG.-DE-FR Language selection	CAGE START <small>Weld start by closing spark protection</small>	BURR TEMP TIME	BURR HEAT-POW	MAN. HEATPOW	M-HEAT TIME	
mm	Yes/No	Vor / Zurück	ON/OFF	single / double	Semi- / Fully	>ENG.	Yes / No	sec	%	%	sek	
27x0.90	C	D	D	single	Auto	EN	Yes					
27x1.10	C	D	D	single	Auto	EN	Yes					
34x0.90	C	D	D	single	Auto	EN	Yes					
34x1.10	C	D	D	single	Auto	EN	Yes					

MACHINE SERVICE

The machine is almost Service Free; there are just few points to care.

NOT= The devices which is marked with “ * “ they are the Optional Devices

<u>Device or part</u>	<u>Life</u>	<u>Frequent to change or service</u>
• *Hydraulic Oil	2000 Hours	Monthly to check the level Average all 4 years to change
• Fiber Spark Protections	500 Days Average	Change when broken or burn by spark
• *Cooling Liquid	4 Years	Monthly to check the level Average all 4 years to change
• Machine inside		twice a year

Open all Doors and plates around the Machines to see inside, use an vacuum cleaner to clean the machine free from dust. Attention, plug out the machine from Power and Press-Air when you will do this operation.

- Clamping Jaws depends Weld number frequently to check, weekly
Re-Grind until limited size
Change when no more regrinding
Possible

After any change of clamping jaws have to be made the calibration procedure with Carbon Papers.

- Band Alignment Stoppers Weekly to check and adjust

The numerical adjusters of stoppers have to be checked by supplied alignment gauge.
A cleaning and grassing service is needed especially if they are difficult to turn.

- *De-Burring System Edges 6month/when broken Weekly to check and/or to change

CLAMPING JAW SERVICING / GRINDING INSTRUCTIONS

The Top-Jaws are Steel and the regrinding period is longer than the Lower-Jaws.
The re-grind able volume is 4 mm, keep 1 mm as last, do not grind down less than this 1 mm.
The Lower-Jaws are a type of Bronze; Temelsan is using the Ampco-Bronze, hard and very high connectivity. The re-grind able volume is 6 mm, keep 1 mm as last, do not grind down less than this 1 mm.

Grind anytime pair wise, keep the parallelism by less than 2 hundredths mm, Tol: +/- 0.01

The Connectivity is very important, which why it's forbidden to grease or oil the surface of jaws.
The reasons to regrind the Jaws are the dirty surface which reduce the connectivity and the mechanically deformation after many clamping and un-clamping.

For Welds out of precision are usually the Jaws and there precision and condition responsible.



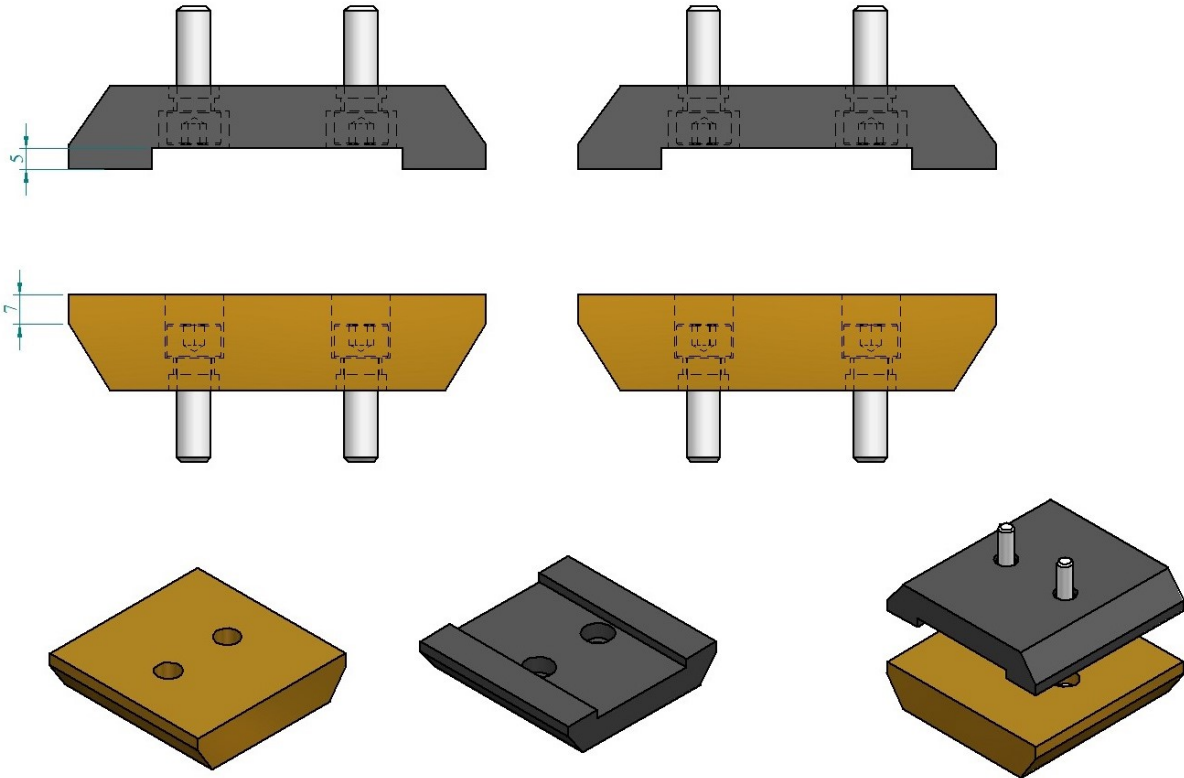

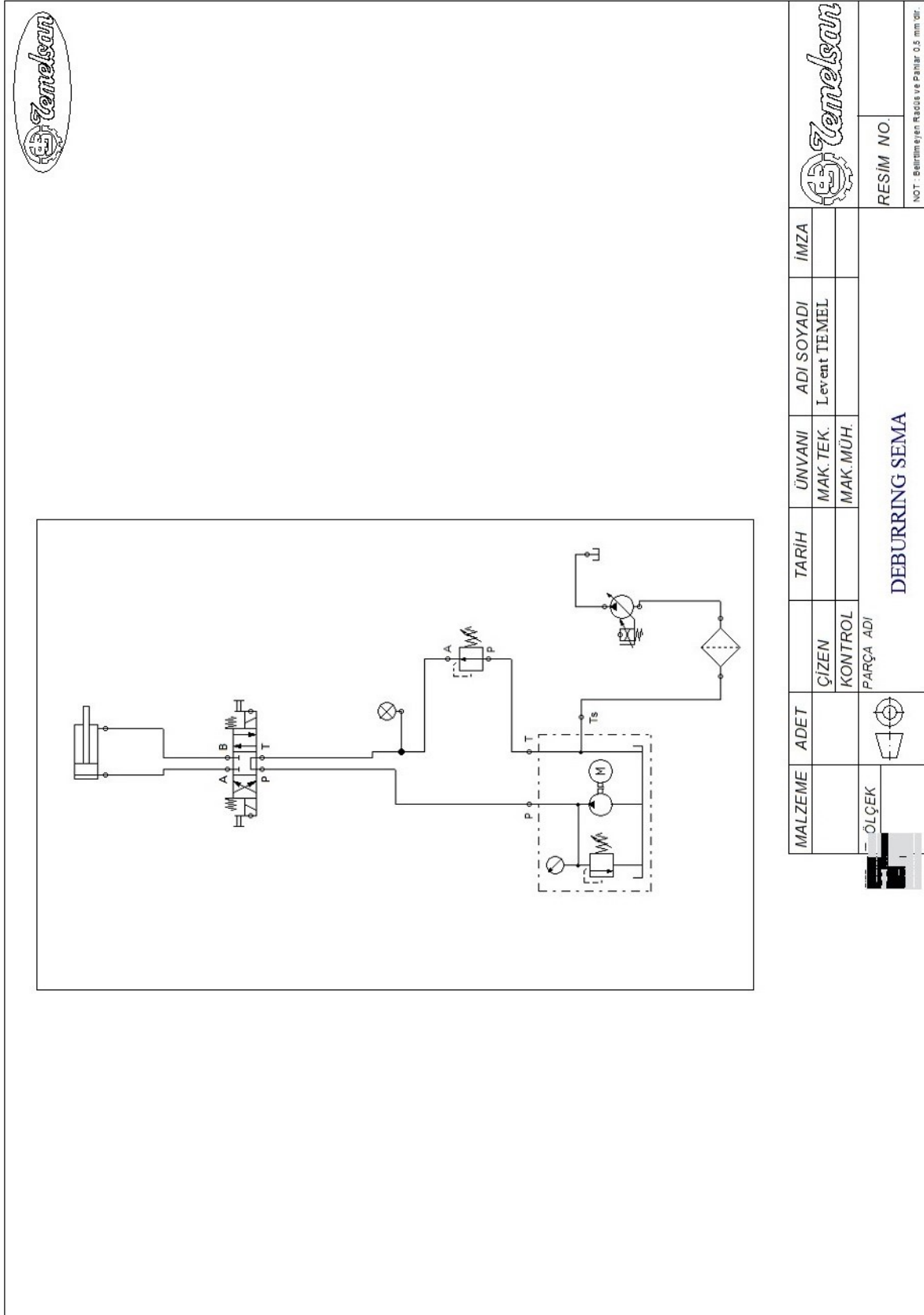

After any Change of Jaws, please run the Carbon Paper calibration.





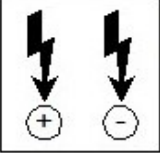





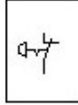
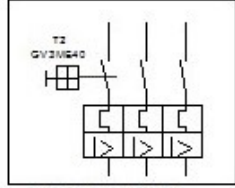

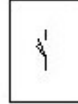

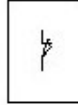
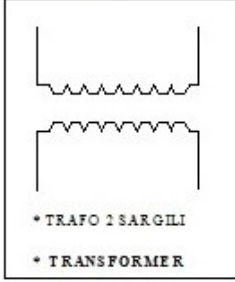
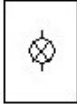
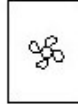
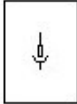
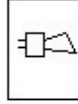

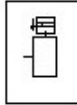

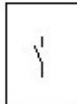

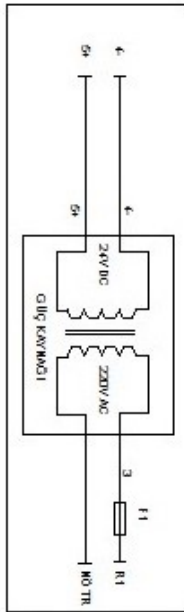
MALZEME	ADET	ÇİZEN	TARİH	ÜN VANI	ADI SOYADI	İMZA
		KONTROL		MAK. TEK.	Levent TEMEL	
		PARÇA ADI		MAK. MÜH.		
RESİM NO.						
RESİM NO.						

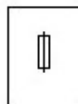
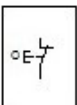
NOT: Belirtilen eğer Resolu ve Panhar 0.5 mm dir.

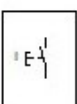
8		DİKKAT ! CAUTION!					
7	ELEKTRİK VERİLMEDEN ÖNCE UYGULANMASI GEREKEN GÜVENLİK TEDBİRLERİ						
6	SAFETY PRECAUTIONS BEFORE INSTALLATION OF INPUT POWER						
5		*ŞEBEKE GERİLİMİNİN 380 VOLT OLDUĞUNDAN EMİN OLUNUZ. *MAKE SURE THAT THE MAIN VOLTAGE IS 380 VOLT.					
4		*ELEKTRİK TESİSAT HATTİNİZİN UYGUN OLDUĞUNDAN EMİN OLUNUZ. *MAKE SURE THAT THE ELECTRICAL UTILITIES ARE PROPER TO USE.					
3		*TOPRAKLAMA TESİSATINIZI SERTİFİKALI BİR ELEKTRİKÇİYE YAPTIRMAYI İHMAL ETMEYİN. TOPRAKLAMA YAPILMADAN KULLANIM HALİNDE ORTAYA ÇIKABİLECEK HATALARDAN FİRMAMIZ SORUMLU DEĞİLDİR. *MAKE SURE THAT THE GROUND INSTALLATIONS DONE BY A QUALIFIED ELECTRICIAN. THE MANUFACTURER HAS NO RESPONSIBILITY IF THE MACHINE IS INTENDED TO BE USED WITHOUT GROUNDING.					
2		*ELEKTRİK PANOSUNU DİŞ ETKENLERE KARŞI KORUMAK İÇİN KAPAGINI DAİMA KAPALI TUTUNUZ. *KEEP THE ELECTRICAL CABINET ALWAYS CLOSED TO PROTECT FROM EXTERNAL FACTORS AND INTERVENTION OF THIRD PARTIES.					
1		*DİKKAT! YUKARIDAKİ ÖNLEMLERE UYULMADIĞI TAKİRDE FİRMAMIZ HİÇBİR SORUMLULUK KABUL ETMEMEKTEDİR. *ATTENTION! YOU MUST OBEY TO THE SAFETY PRECAUTIONS IF NOT; THE MANUFACTURER DOES NOT ACCEPT ANY RESPONSIBILITY BECAUSE OF THE CAUSE OF DAMAGE.					
0	A	B	C	D	E	F	
						TALİ MATLAR	DOĞRU NO: SAYFA: 1

8	*İLETKENLERİN BAĞLANTISI *CONDUCTOR CONNECTION		*KENETLEMELİ MANTAR BUTON *CLAMPING TYPED PRESS BUTTON		 <p>*MOTOR KORUMA *MOTOR PROTECTION</p>
7	*KLEMENS BAĞLANTISI *TERMINAL CONNECTION		*AÇIK SVİÇ *SWITCH TURNED ON		
6	*GENEL TOPRAKLAMA *MAIN GROUNDING		*KAPALI SVİÇ *SWITCH TURNED OFF		 <p>*TRAFO 2 SARGILI *TRANSFORMER</p>
5	*LAMBA *LIGHT		*PANO HAVALANDIRMA FANI *CONTROL PANEL VENTILATION FAN		
4	*FİŞ/PRİZ BAĞLANTISI *PLUG CONNECTION		*SİREN *SIREN		 <p>*ÜÇ FAZLI MOTOR (AC) *THREE PHASE MOTOR (AC)</p>
3	*HİDROLİK VALF BOBİNİ *HYDRAULIC VALVE COIL		*MOTOR KORUMA TERMİK KONTAĞI AÇIK *MOTOR SAFETY THERMIC SWITCH ON		
2	*NORMALDE AÇIK KONTAK *SWITCH TURNED ON		*MOTOR KORUMA TERMİK KONTAĞI KAPALI *MOTOR SAFETY THERMIC SWITCH OFF		 <p>POWER SUPPLY</p>
1	*NORMALDE KAPALI KONTAK *SWITCH TURNED OFF		*SİGORTA *SAFETY FUSE		
0	*KAPALI BUTON *TURNED OFF BUTTON		*İŞIKLI AÇIK BUTON *LIGHTED BUTTON TURN ON		
	*AÇIK BUTON *TURNED ON BUTTON		*AYDINLATMA *LIGHTING		
	*SENSÖR *SENSOR				

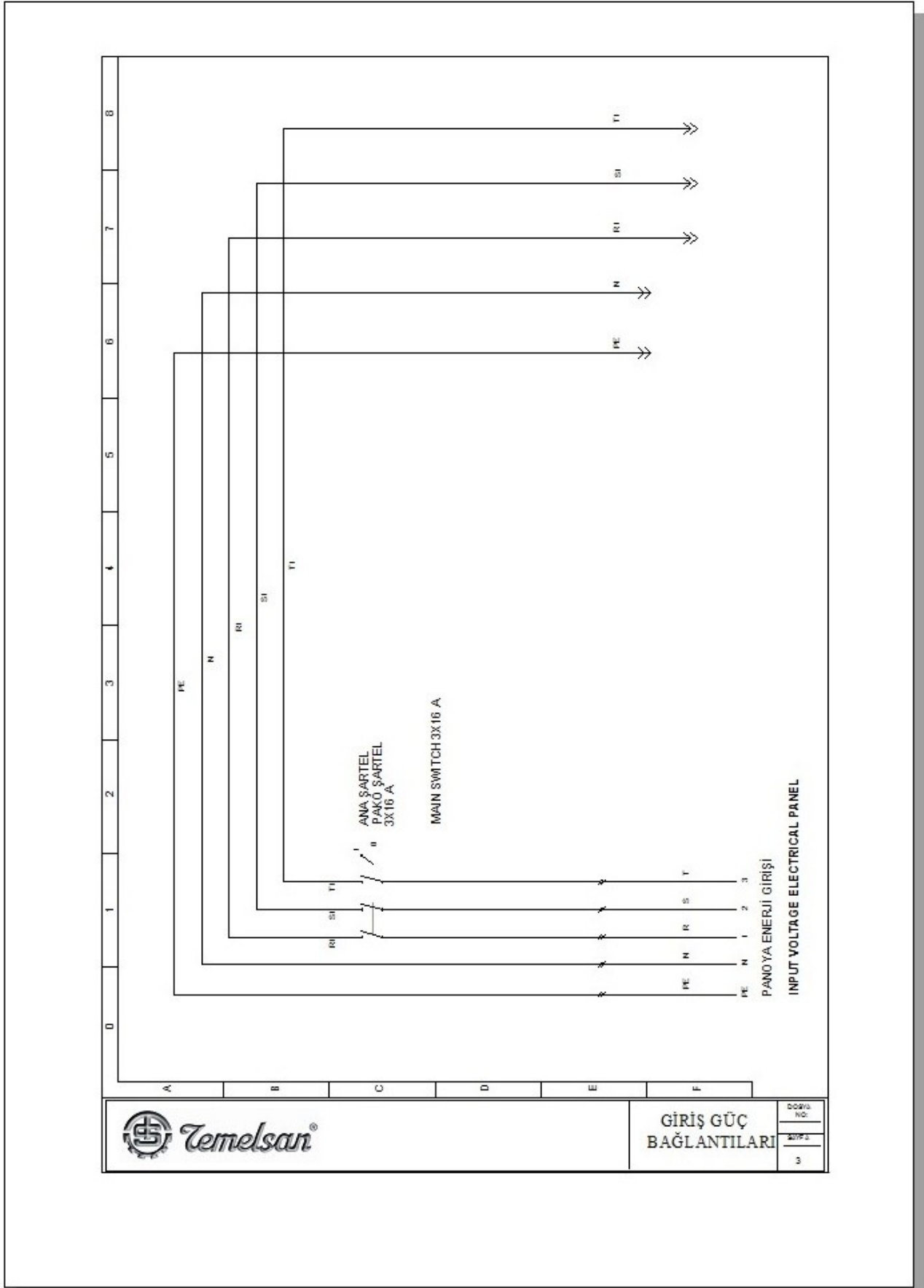

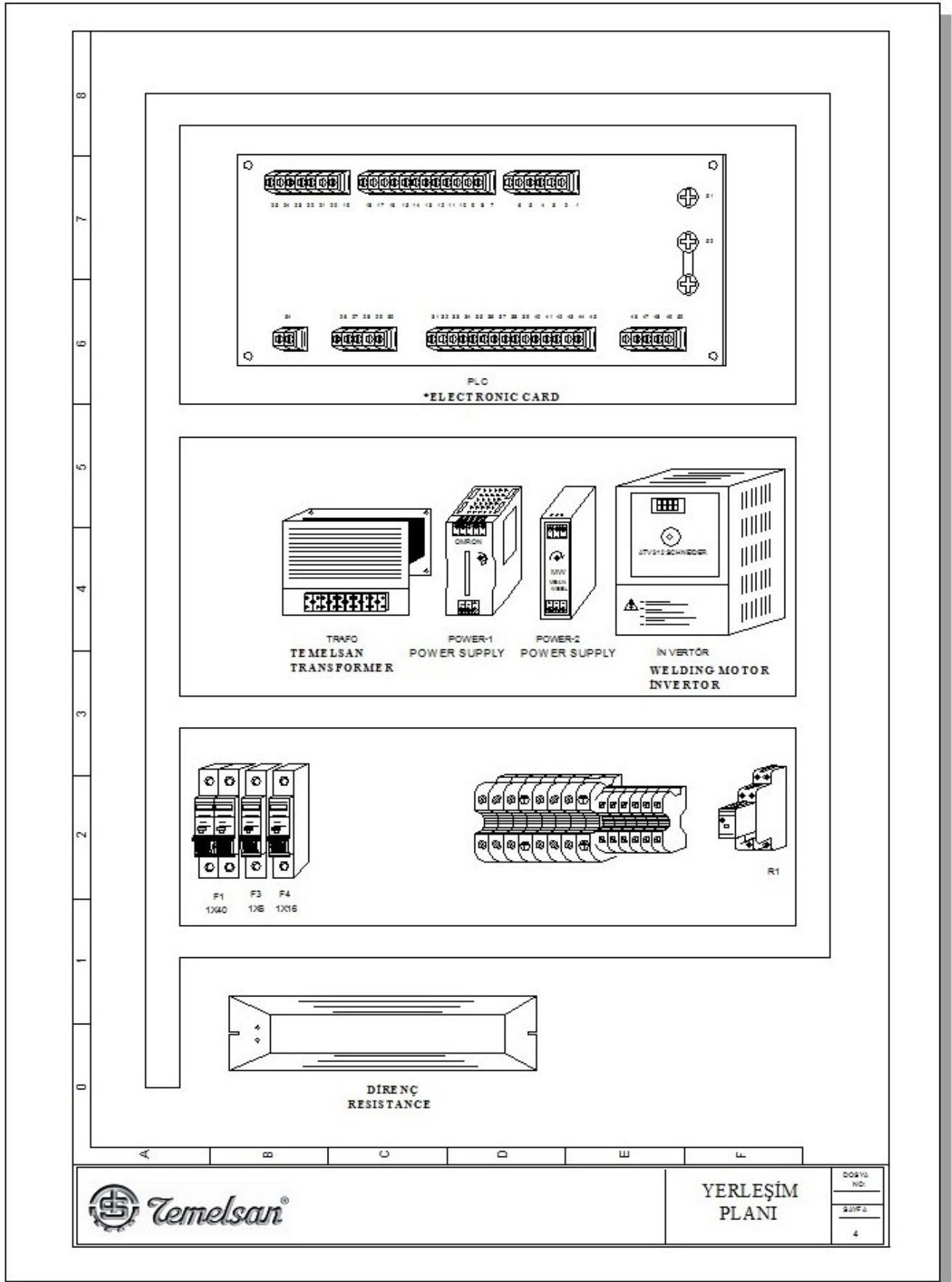

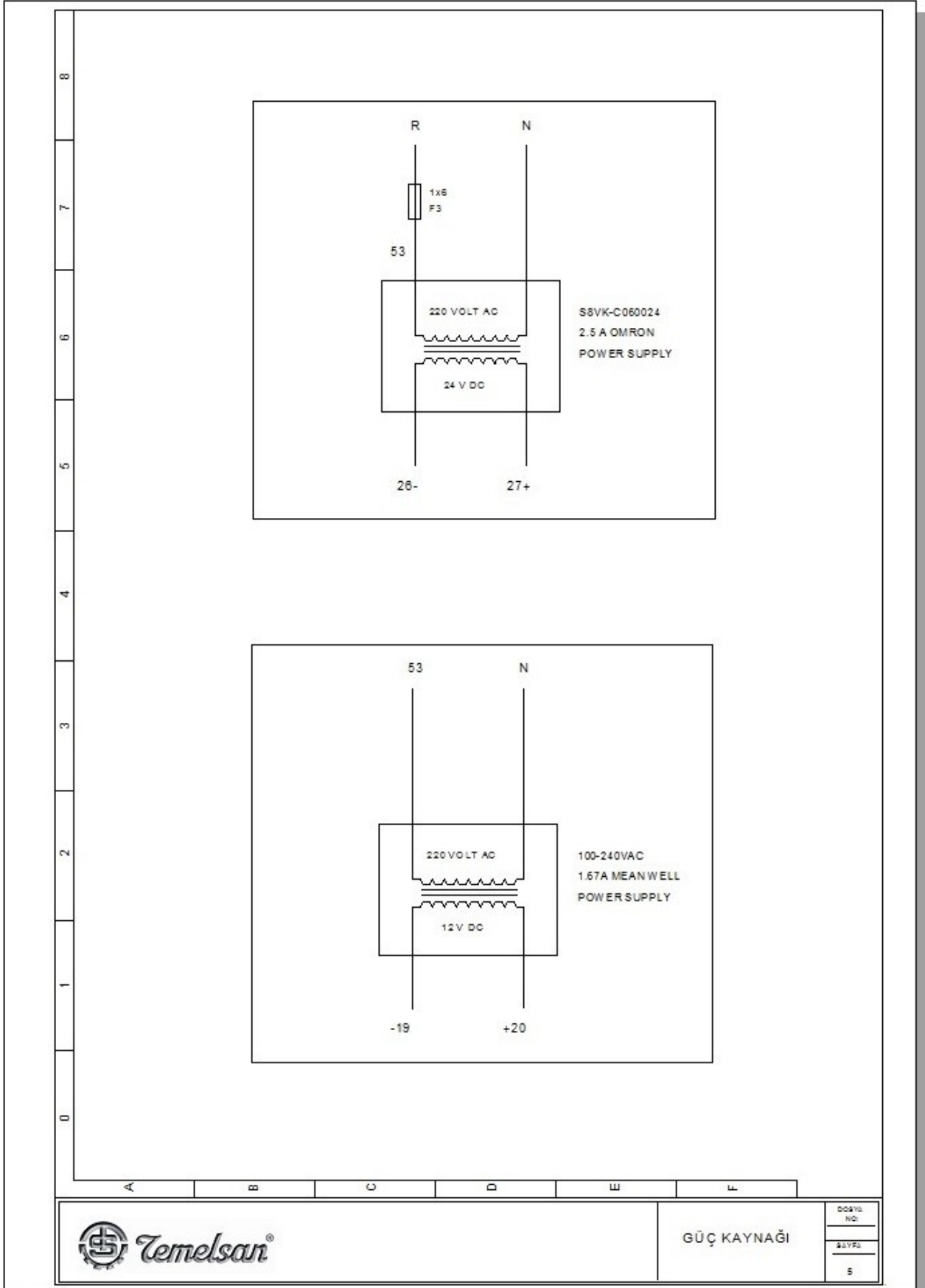

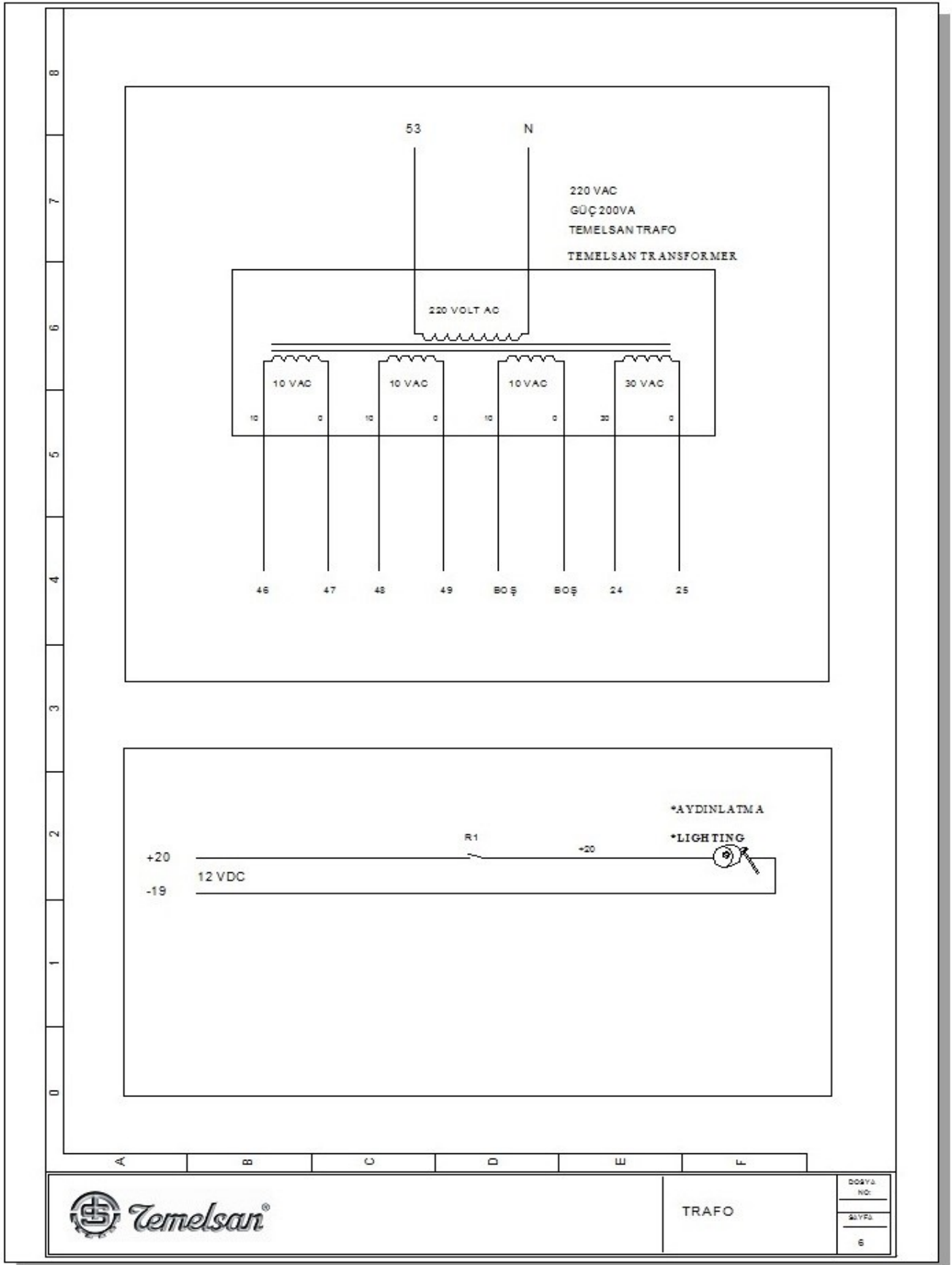

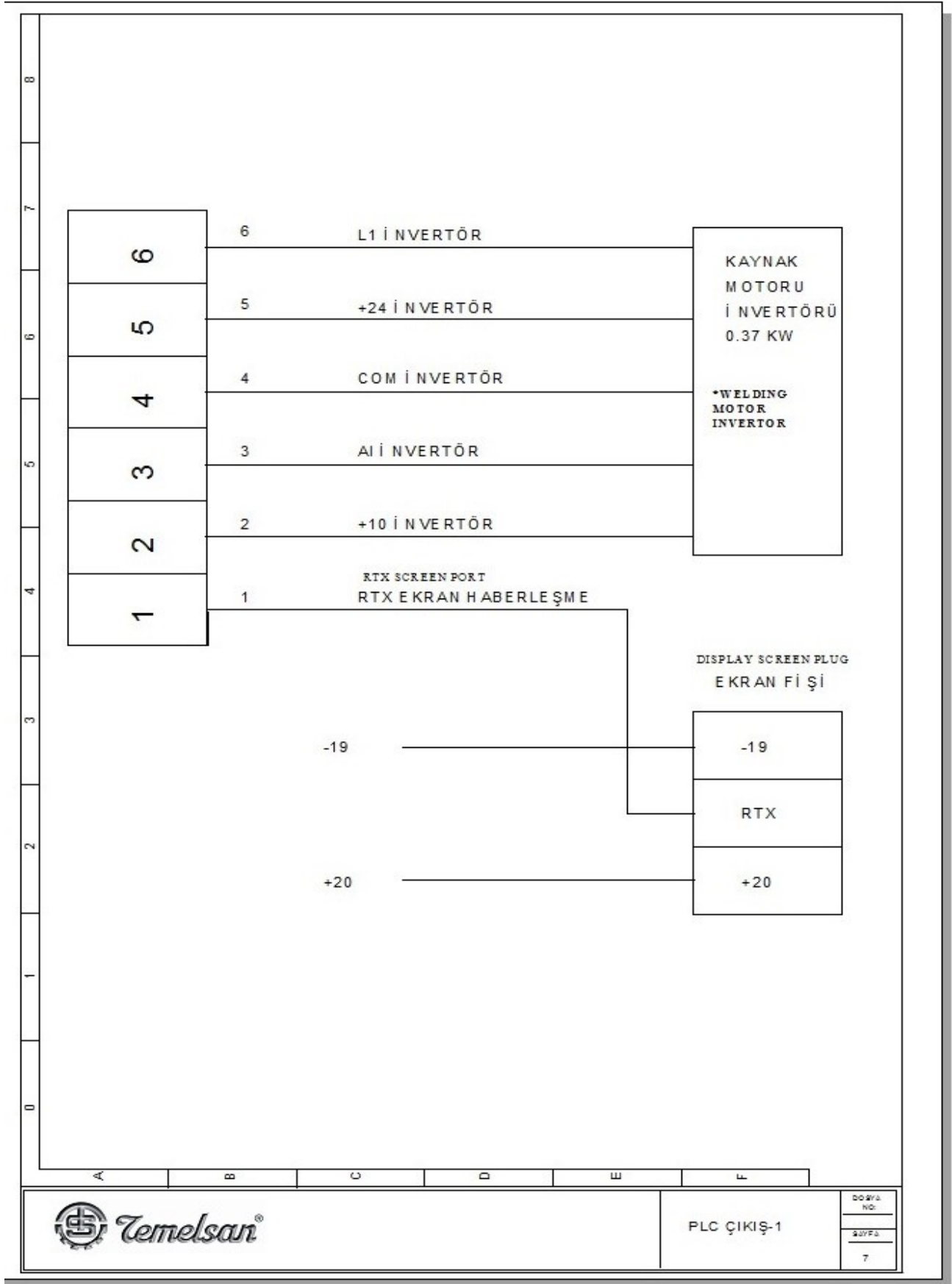

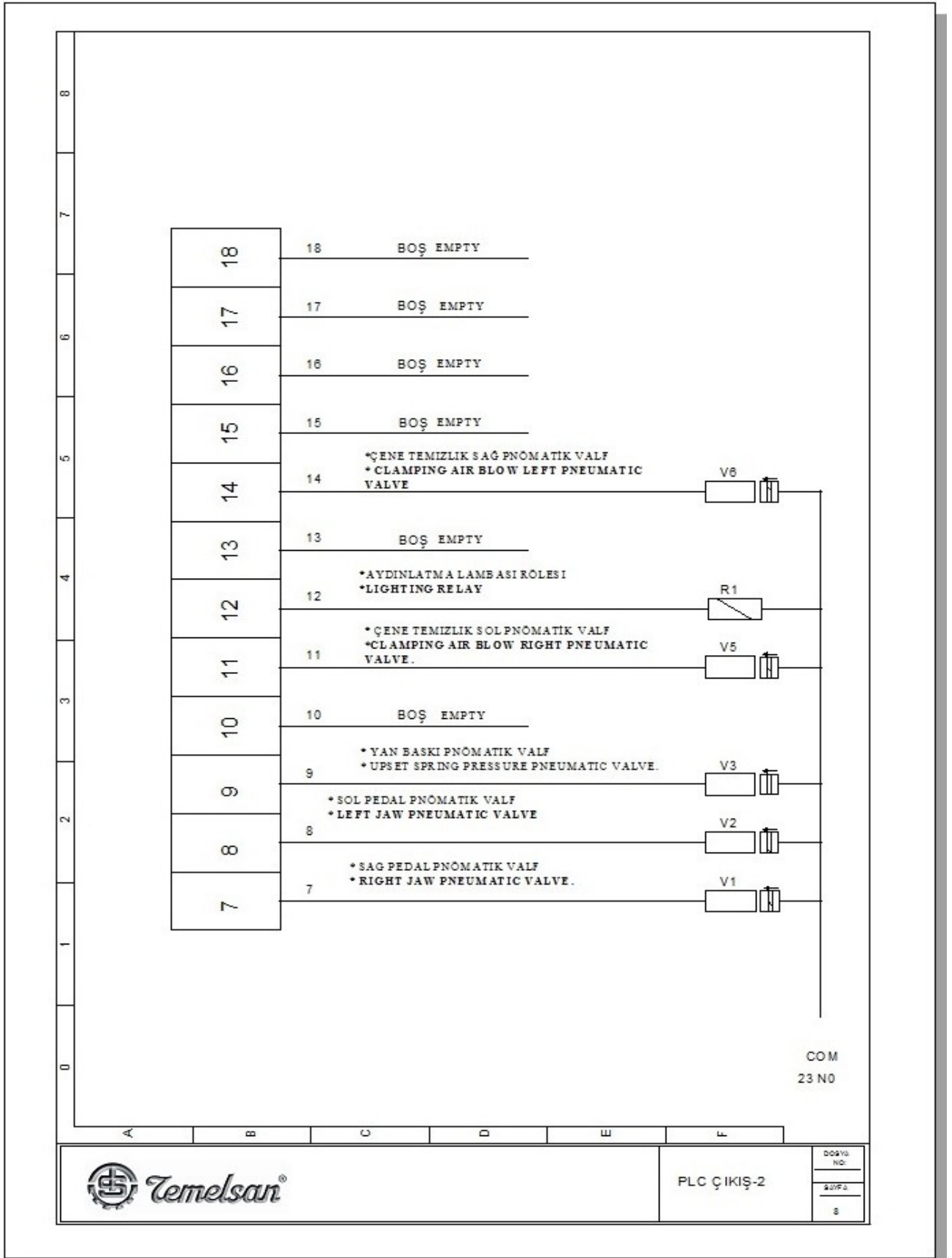

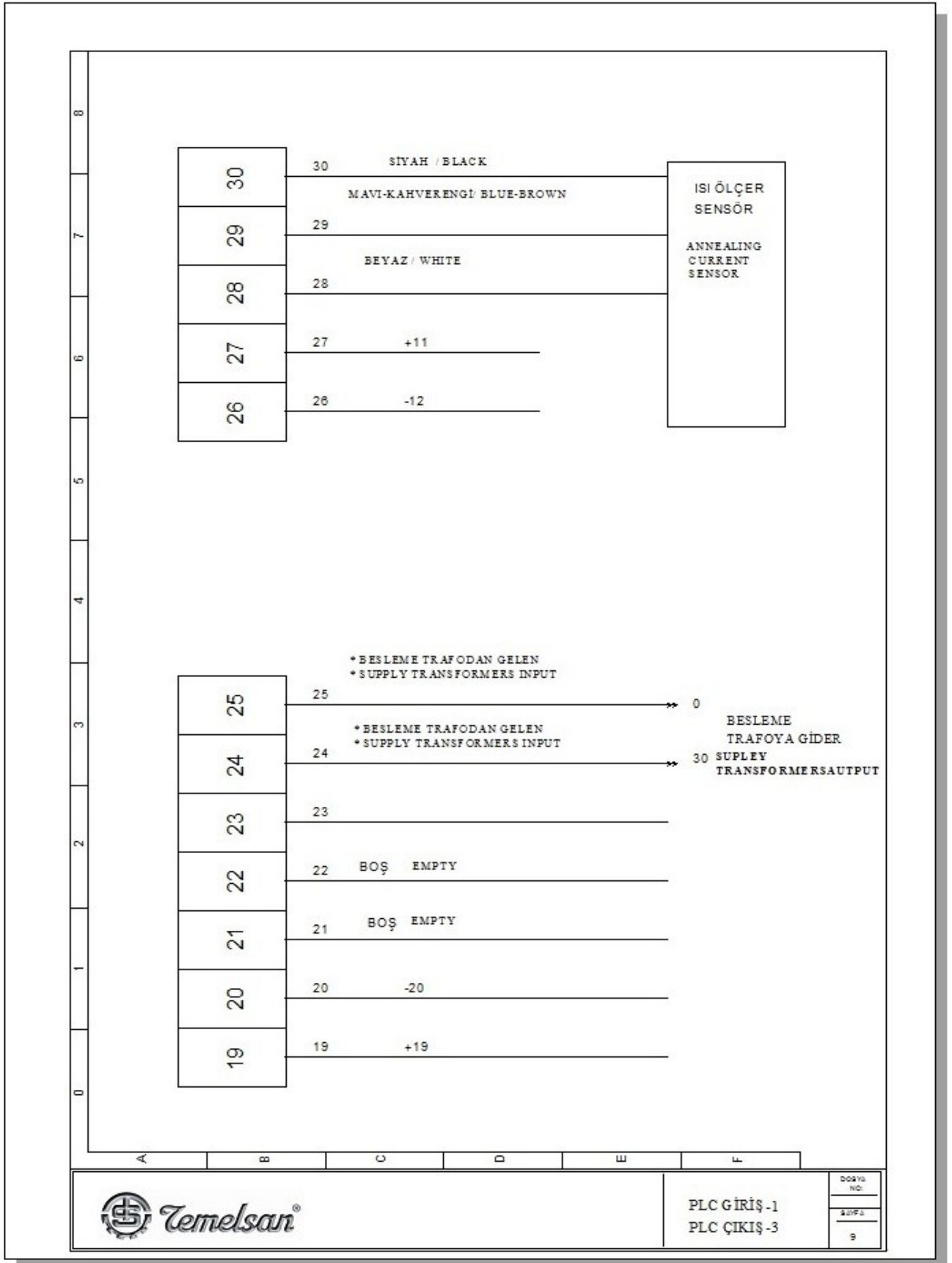

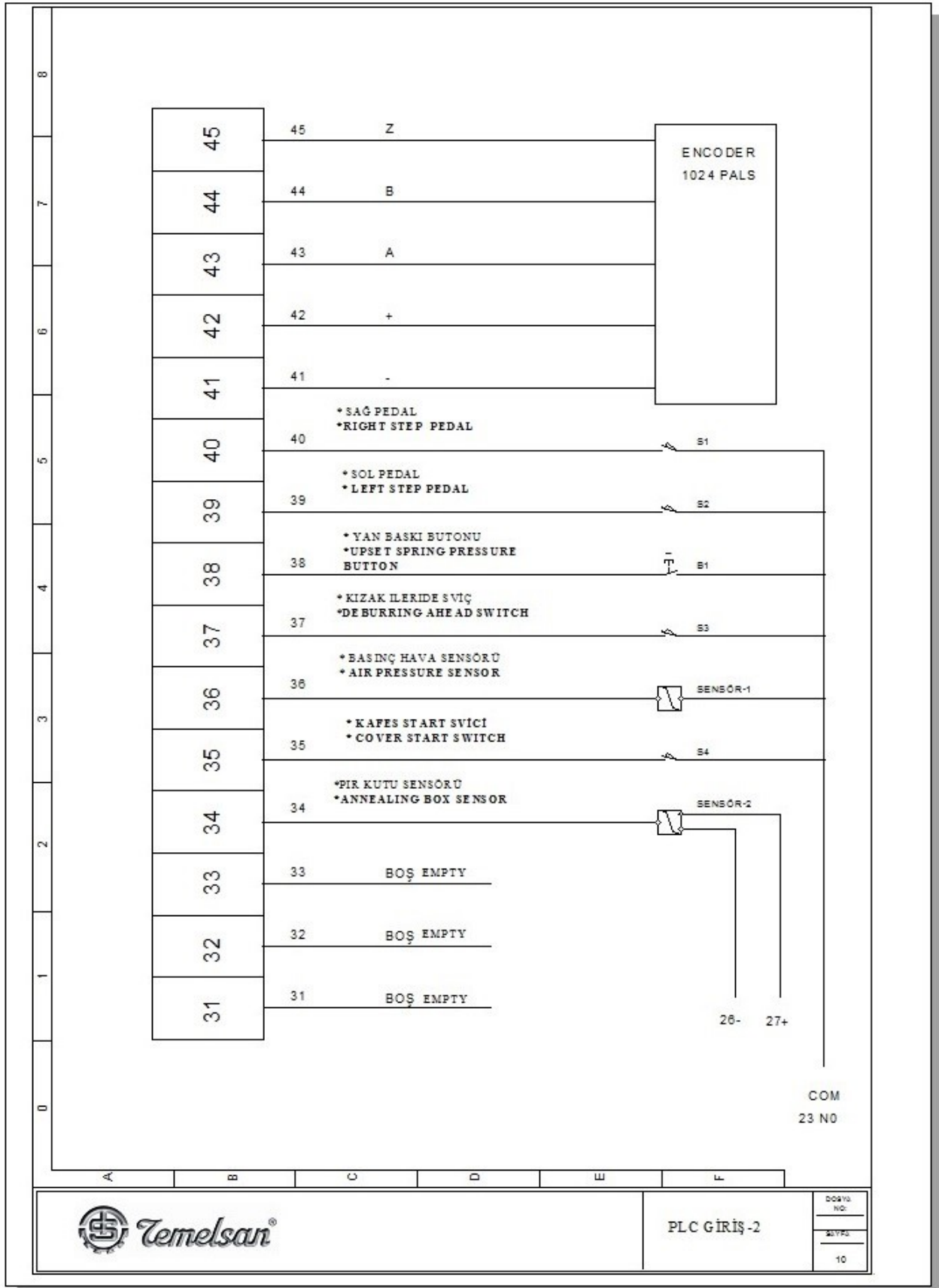

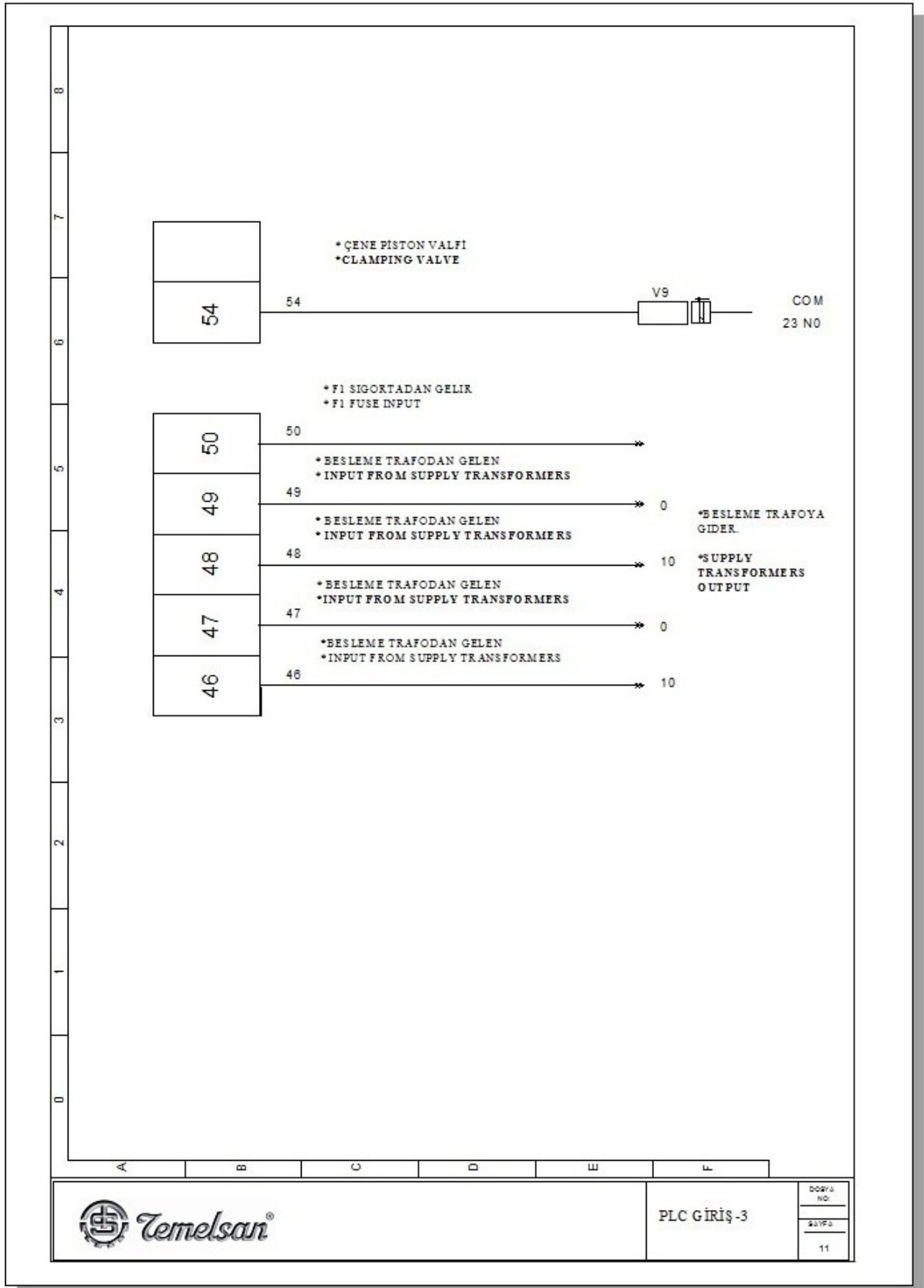

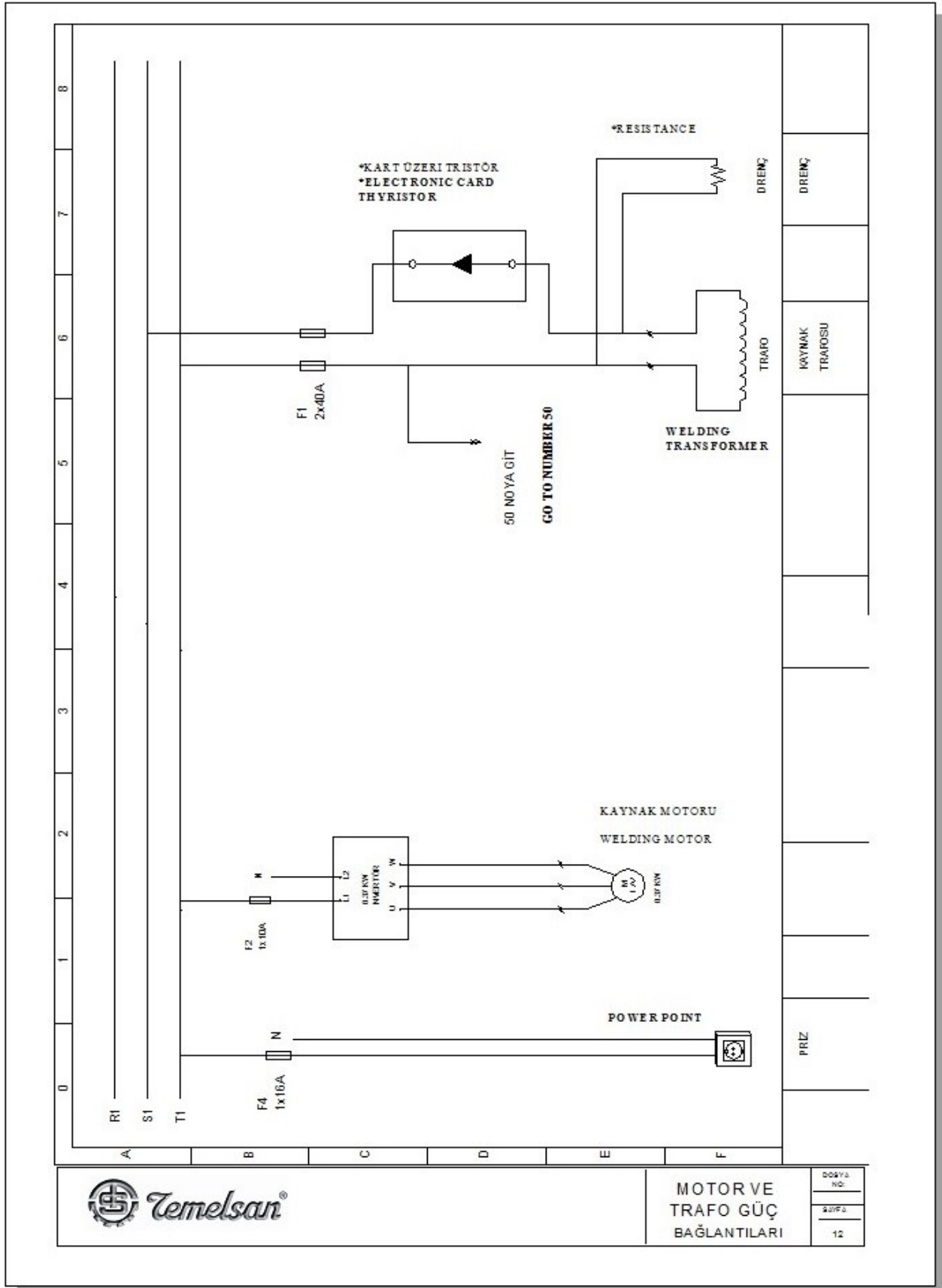

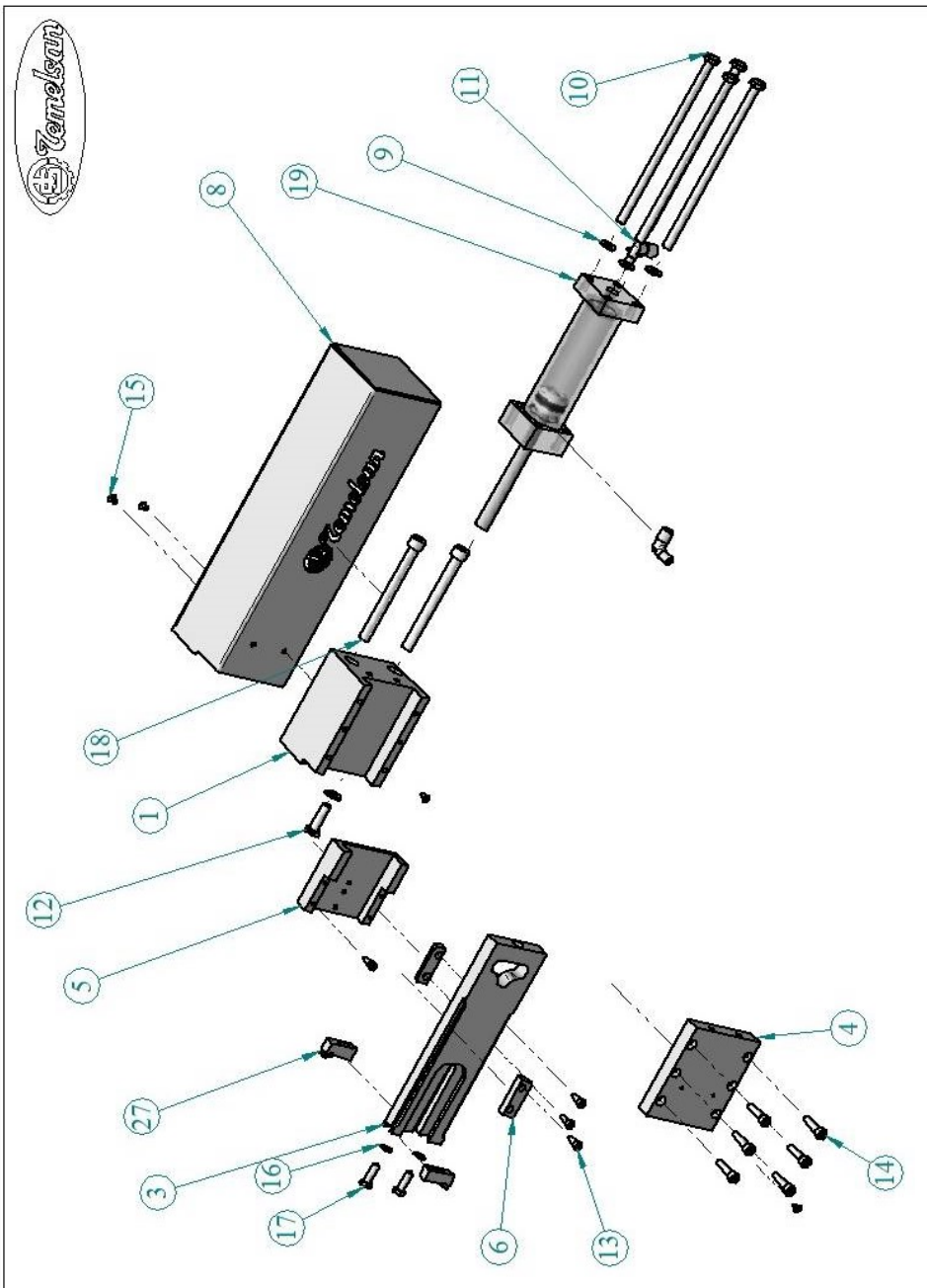





RESİM NO.

NOT : Belirtilmeyen Rastgele ve Panjalar 0.5 mm'dir.

Item Number	File Name	MALZEME	ADET	ÇİZEN	TARİH	ÜNVANI	ADI SOYADI	İMZA
1	YATAK ARKA 01.par			KONTROL		MAK.TEK.	Levent TEMEL	
3	LEM.A.par			PARÇA ADI		MAK.MÜH.		
4	YATAK KAPAK 01.par							
5	YATAK .par							
6	YATAK KARŞILIĞI.par							
8	MUHAFAZA SACI 01.psm							
9	Pim 10 .par							
10	ABM 10X230.par							
11	Drsl1414 D .par							
12	ABM 10X35.par							
13	Im6x15.par							
14	IM8X30.PAR							
15	YTBM5x8.par							
16	Pim8.par							
17	Abm8x25.par							
18	IM12X130.par							
19	ARKA KAPAK.par							
20*	KEÇE YATAK.par							
21*	MİL.par							
22*	Kastar Seals-K18-40X26X15_5X36X2_6.asml							
23*	Kastar Seals-KO-35X2_5.par							
24*	BORU.par							
25*	ON KAPAK.par							
26*	ELMAS LEMASI.par							
27	ELMAS.par							
28*	HBAL4x10.par							

ÇAPAK SIYIRICI.asm

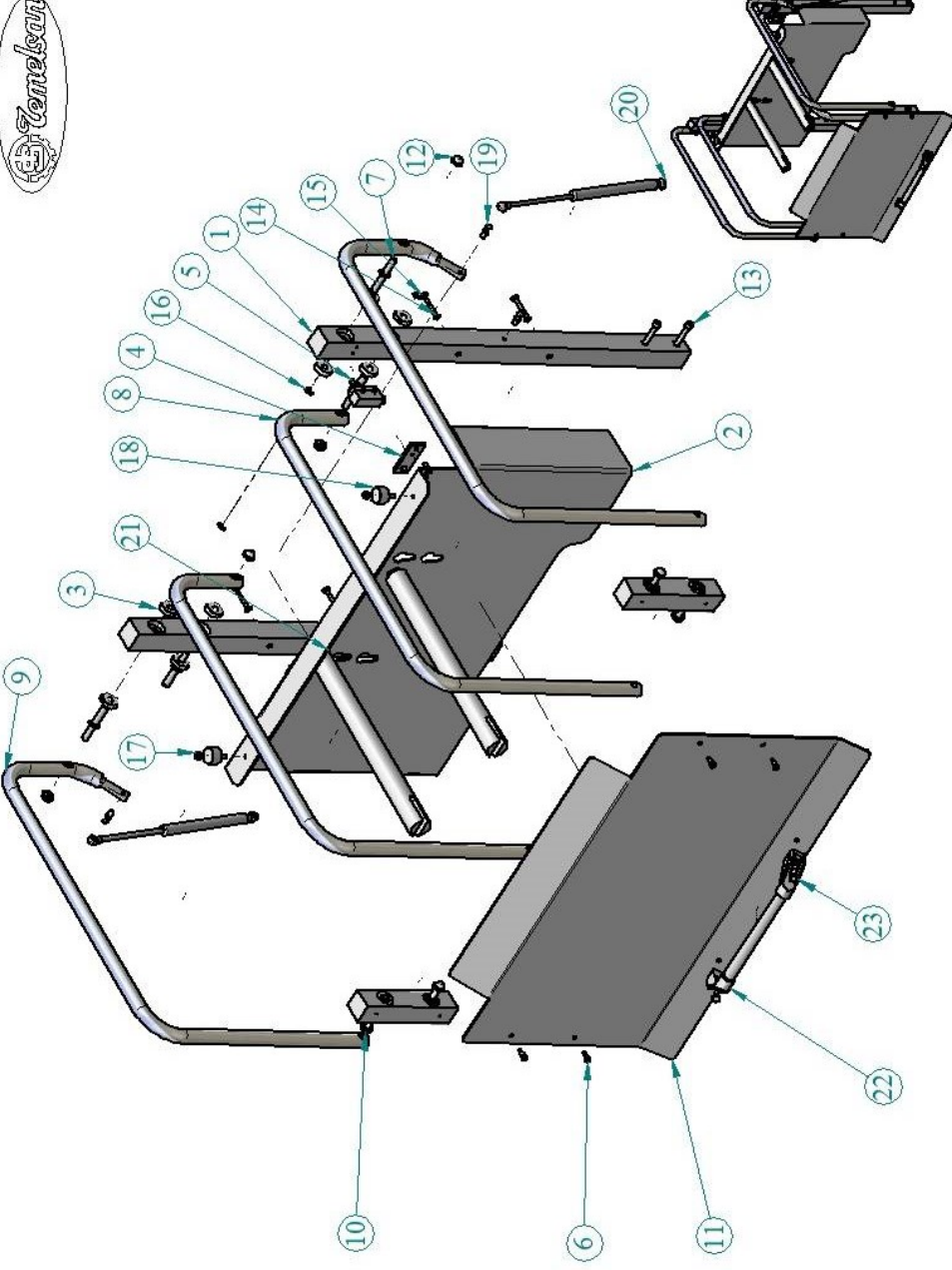
Item Number	File Name
1	ARKA ŞASE 02.par
2	ARKA SAC 02.psm
3	6201.par
4	SIVIC LEMASI.par
5	MOJUN M12-1307 KAPAKLI.asn
6	Im6x15.par
7	P1M.par
8	KOL Y IC.par
9	KOL Y DIS.par
10	ÖN KAPAK BALANLI TAKOZ MONTAJ.asn
11	ÖN KAPAK.psm
12	SML12 TOPUZ.par
13	IM8X45.par
14	P1m6.par
15	ABM6X50.PAR
16	SML12.par
17	Sm8.par
18	LASTIK TAKOZ.par
19	AMORTISOR BALANLI M8 KURE.par
20	VAS AMORTISOR 250N.par
21	TES ASKI.par
22	ALM KAPAK KOL.par
23	Abm8x20.Par

MALZEME	ADET	ÇİZEN	TARİH	ÜN VANI	ADI SOYADI	İMZA
		KONTROL		MAK.TEK.	Levent TEMEL	
				MAK.MUH.		

HBA KAPAK MONTAJ .asm

RESİM NO.

NOT: Belirtilen Resim ve Parçalar 0.5 mm dir.

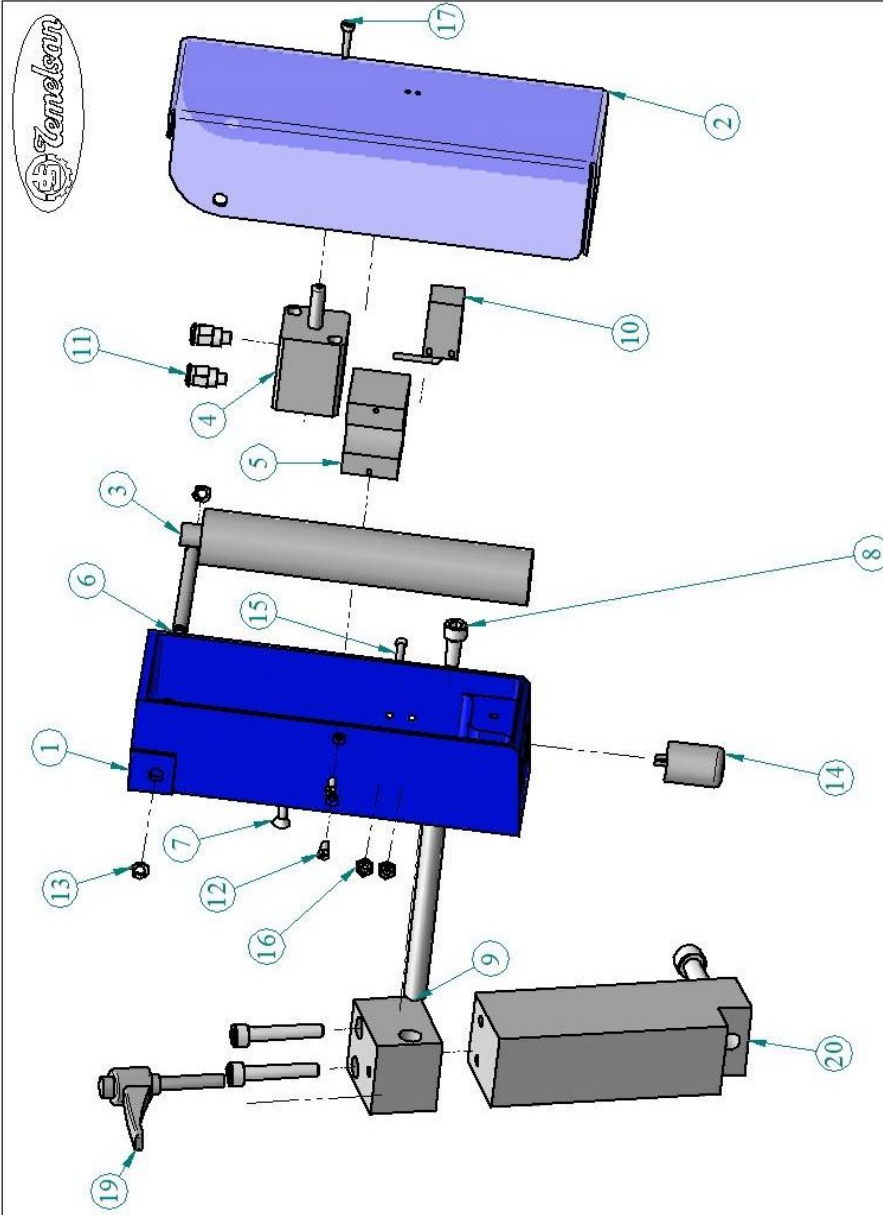



MALZEME	ADET	ÇİZEN	TARİH	UNVANI	ADI SOYADI	İMZA
		KONTROL		MAK.TEK.	Levent TEMEL	
		PARÇA ADI		MAK.MÜH.		
		ÖLÇEK		● ISI KUTU.asm		
						RESİM NO
						NOT: Belirli bir Rastis ve Pinar 0.5 mm dir.

POSITION	File Name
1	KUTU.par
2	KUTU SAC.psm
3	IGA 310.par
4	PI-STON 16X15.par
5	ISI BAGLA.par
6	KAPAK PİMİ.par
7	HBAL4x10.par
8	Im6x15.par
9	ISI KUTU MİL.par
10	ISI KUTU SENSÖR LE17TSN08DPO.par
11	REKÖR IM5-4.par
12	HBY 3x10.par
13	SML6.par
14	LED LAMBA 12V DC.par
15	HBY 3x20.par
16	SM3.par
17	IM 3X20.par
19	BK M6 KOL.par
20	ısı ölçer bavlama lema KN100.par
21*	ISI ÖLÇER TAKOZU ÜST HBA.par
22*	Im6x35.par
23*	IM 8X25.par

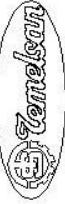

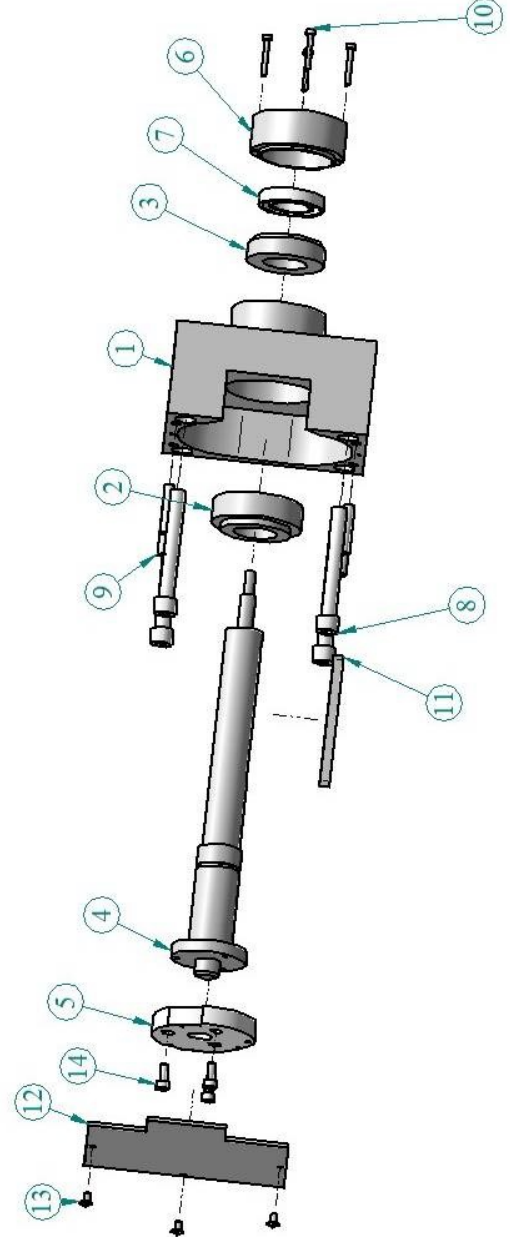

POSITION	File Name
1	KAM YATAK GÖVDE.par
2	32207 KONİK RULMAN.par
3	32007X 35X62X18.par
4	KAM YATAK ANA MİL DENE.par
5	KAM-KN-100.GEN İS MENEVİSLİ EN SON.par
6	KEÇE KAPAK.par
7	30x52x10 YA .par
8	İM12X90.par
9	STM8X4.0.PAR
10	İM4X30.par
11	KAMA8X8.par
12	YATAK KAPAK.par
13	YTBM5x8.par
14	İM6X15.par

MALZEME	ADET	ÇİZEN	TARİH	ÜN VANI	ADI SOYADI	İMZA
		KONTROL		MAK. TEK.	Levent TEMEL	
		PARÇA ADI		MAK. MÜH.		



ÖLÇEK

KAM YATAK MONTAJ.asm



RESİM NO.

NOT: Belirtilmeyen Radüs ve Pahaar 0.5 mm dir.

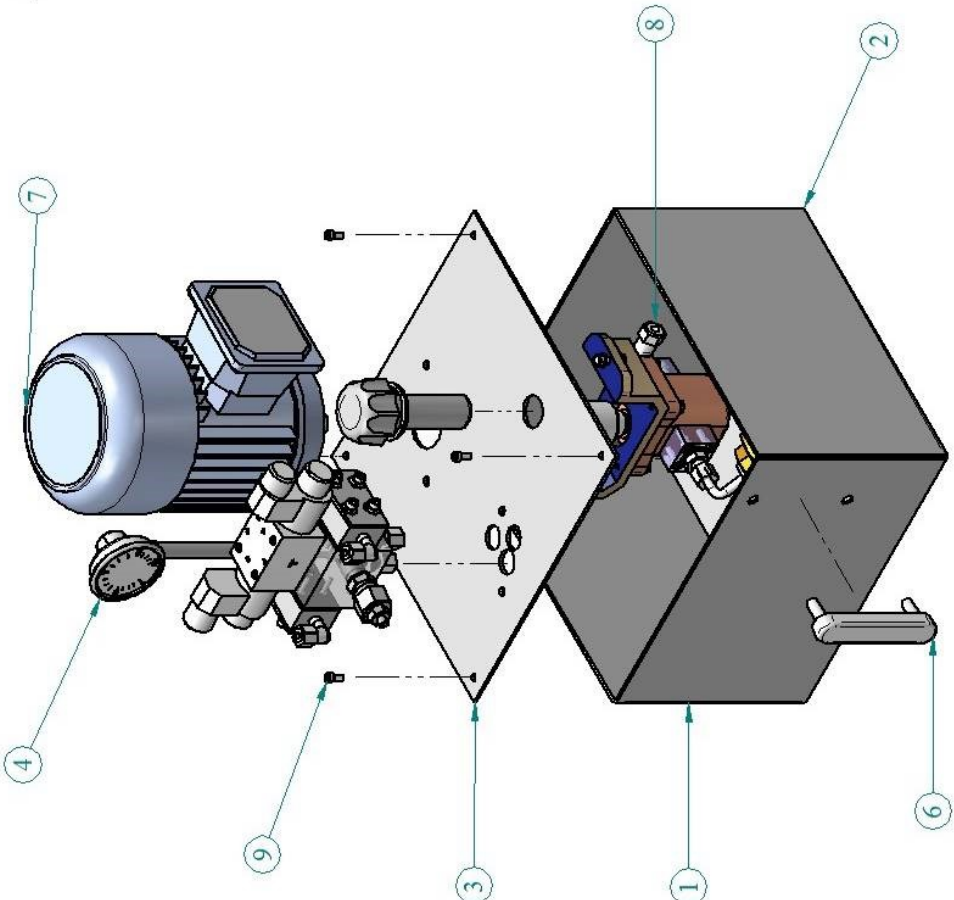
MALZEME	ADET	ÇİZEN	TARİH	ÜN VANI	ADI SOYADI	İMZA
		KONTROL		MAK.TEK.	Levent TEMEL	
		PARÇA ADI		MAK.MÜH.		
KIZAK DEPO.asm						RESİM NO.
- OLÇEK						NOT: Sehimlenen Radüs 0.5 ve Pahaar 0.5 mm dir.

Item Number	File Name
1	DEPO U SAC.psm
2	DEPO L SAC.psm
3	KIZAK DEPO KAPAK.par
4	KZK TAKOZ YENİSİ DÜZELTİLMİŞ .asm
5*	YAV DOLUM DEPO KAPAK 80.par
6	YAV GOSRERGESİ .par
7	80-3F-14.asm
8	POM 9LT WINMAN.asm
9	IM5X15.PAR



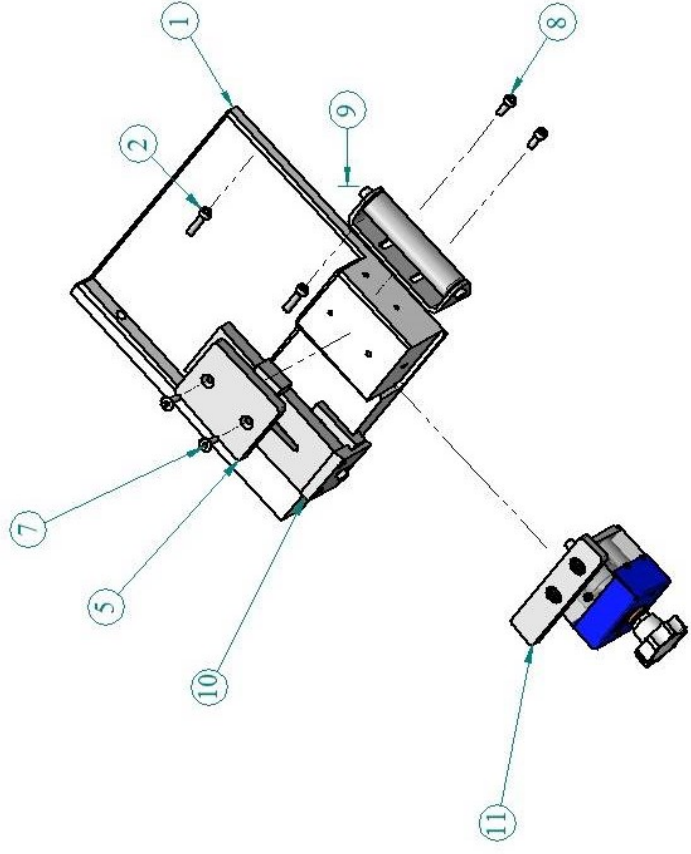

MALZEME	ADET	ÇİZEN	TARİH	UNVANI	ADI SOYADI	İMZA
		KONTROL		MAK. TEK.	Levent TEMEL	
		PARÇA ADI		MAK. MÜH.		
				KNI100 HBA SAG KAPAK.asm		
ÖLÇEK					RESİM NO.	

NOT: Belirtilen Resim ve Parçalar 0.5 mm'lik

Item Number	File Name
1	ALM-SAV-K APAK-KN10 0 Y.par
2	IM6X25.par
5	KAPAK TES AL/IL/IGI.par
7	HBAL6X15. PAR
8	Im6x15.par
9	TESTERE RULO.asm
10	TESTERE SIRT DAYAMA MONTAJ.as m
11	KNI100 NUMARAT ÖR.asm



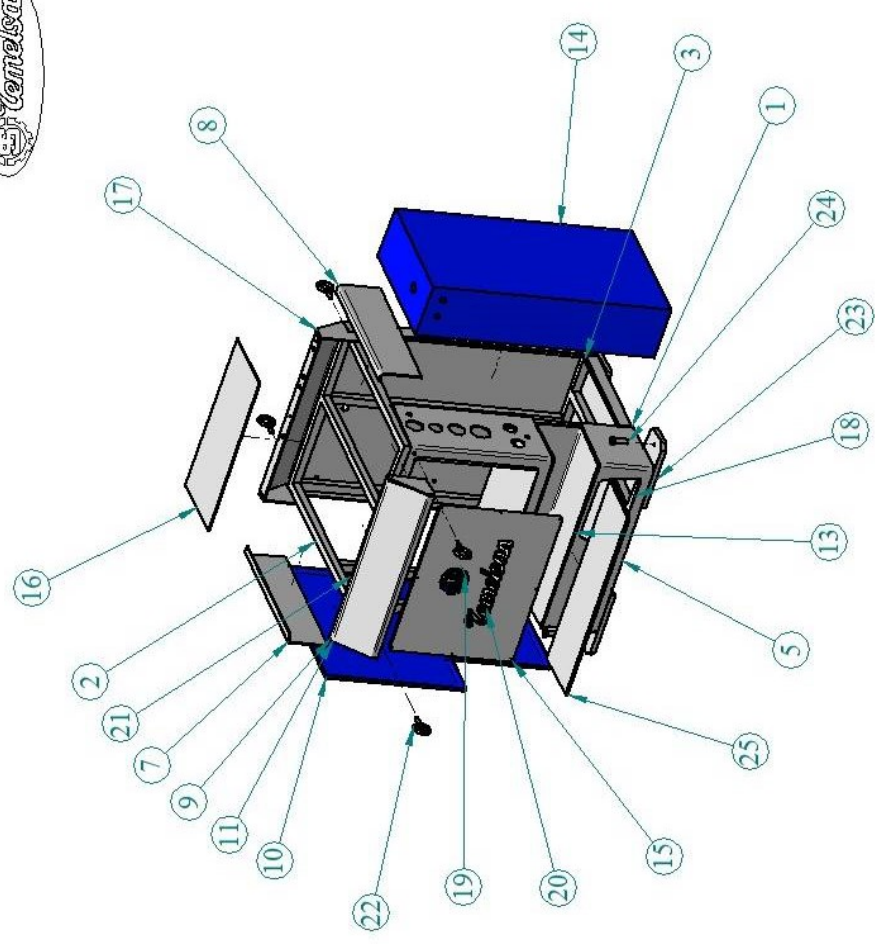

Item Number	File Name
1	ALT ARKA SAC.psm
2	PLAKA ALT.par
3	PLAKA ALTI.par
4*	ON CERCEVE.par
5	ON SAC ALT.psm
6*	ON DIKME.par
7	SOL YAN SAC.psm
8	SAG YAN SAC.psm
9	ON US SAC.psm
10	SOL YAN KAPAK.psm
11	SOL01.psm
12*	TRAF0 ALT.par
13	TES ARA SAC.psm
14	PANO.par
15	ON KAPAK.par
16	ARKA UST SAC.psm
17	ARKA SAG SAC.psm
18	ÇERCEVE ALT.par
19	TRAF0 SA V.par
20	ON KAPAK BAV SAC.par
21	ON SAC DENE.psm
22	M12 MAPA.par
23	SASE AYAK.par
24	AKB16X40.par
25	ŞASE FİBER TES AKIM KEŞ.par

MALZEME	ADET	ÇİZEN	TARİH	ÜNVANI	ADI SOYADI	İMZA
		KONTROL		MAK.TEK.	Levent TEMEL	
		PARÇA ADI		MAK.MUH.		
			KN100 HBA SASE.asm			
- ÖLÇEK			RESİM NO.			
NOT: Belirtilmeyen Radyasyonun Pahalı 0.5 mm dir.						



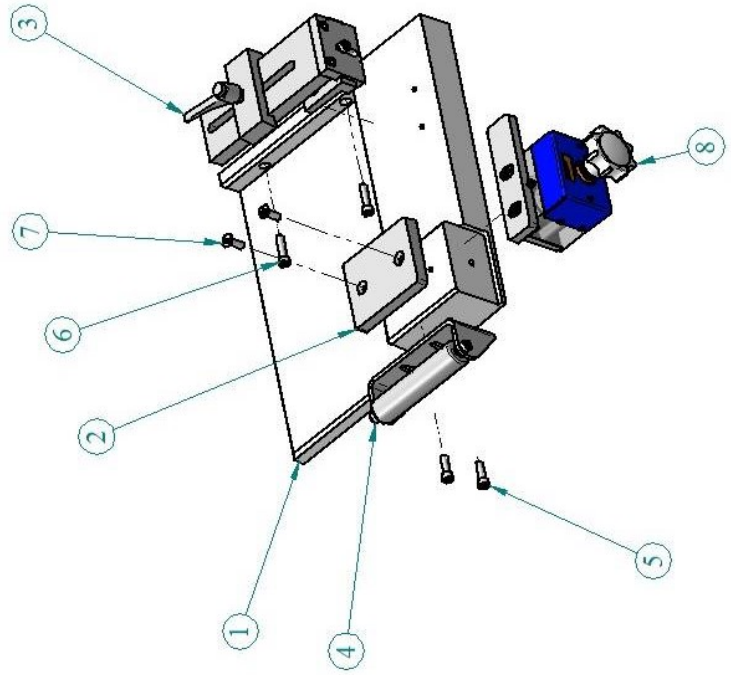



Item Number	File Name
1	ALM-SOL-K APAK-KN10 0 Y.par
2	KAPAK TES ALTILIGI.par
3	TESTERE SIRT DAYAMA MONTAJ.as m
4	TESTERE RULO.asm
5	Im6x20.par
6	IM6X25.par
7	HBAL6X15. PAR
8	KN100 NUMARAT ÖR SOL.asm

MALZEME	ADET	ÇİZEN	TARİH	UNVANI	ADI SOYADI	İMZA
		KONTROL		MAK.TEK.	Levent TEMEL	
		PARÇA ADI		MAK.MÜH.		
KN100 HBA SOL KAPAK.asm						
ÖLÇEK						RESİM NO.

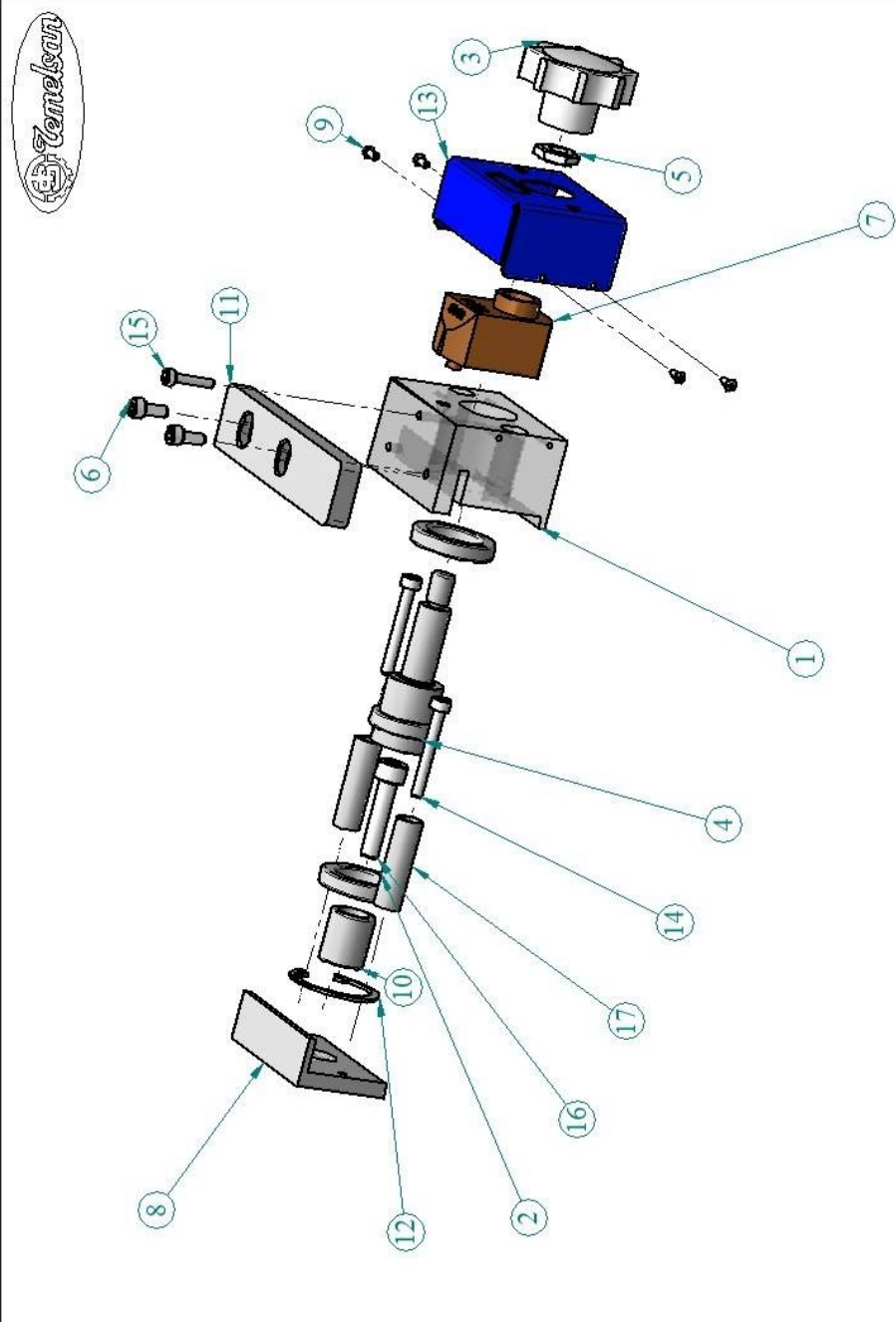
NOT: Belirtilen Redü ve Panir 0.5 mm'dir.



MALZEME	ADET	ÇİZEN	TARİH	ÜNVANI MAK. TEK.	ADI SOYADI Levent TEMEL	İMZA
		KONTROL		MAK. MÜH.		
		PARÇA ADI	KN100 NUMARA TÖR. asmı			
- ÖLÇEK					RESİM NO.	
						NOT : Belirtilen Radius ve Panhar 0,5 mm dir.

Item Number	File Name
1	ANA TAKOZ KN100.par
2	6805 RULMAN.par
3	Bk50x10.par
4	VIDA MILI KN100.par
5	SM10.PAR
6	İM5X15.PAR
7	NUMARATOR DA04.par
8	ALT LEMA KN100.par
9	YTBM3x8.par
10	VI DA KN100.par
11	TES DAYA ÇELİK.par
12	40 SEKMAN.par
13	muhafaza.psm
14	İM5X40.par
15	İM4X20.par
16	İM8X35.PAR
17	MERKEZ PİM.par

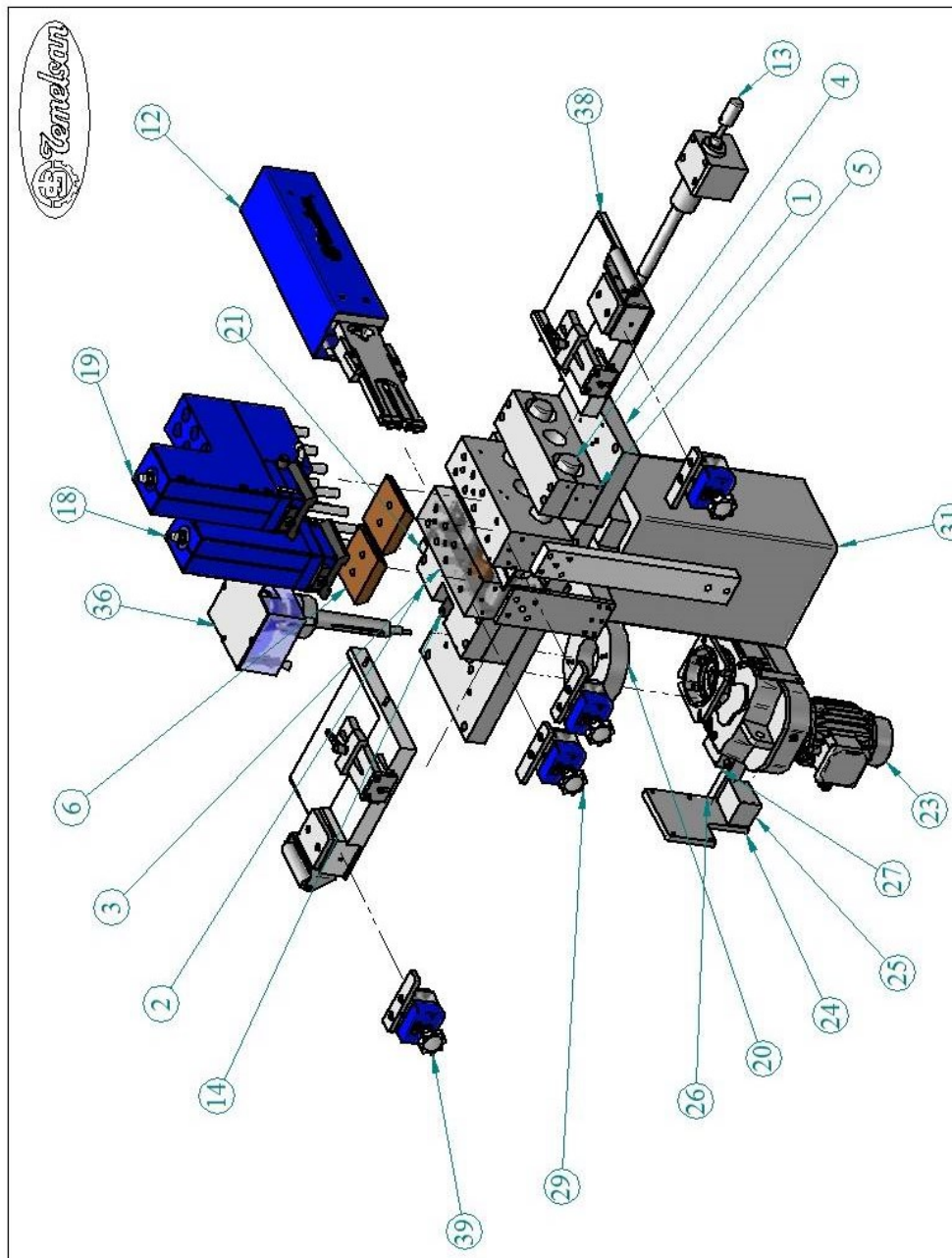



MALZEME	ADET	ÇİZEN	TARİH	ÜNVANI	ADI SOYADI	İMZA
		KONTROL		MAK.TEK.	Levent TEMEL	
				MAK.MUH.		
PARÇA ADI KN100 PLAKA MONTAJ.asm						RESİM NO
ÖLÇEK						NOT: Belirtilmeyen Rasolüve Pahalı 0.5 mm dir.

Item N number	File Name
1	ANA FLAKA.par
2	RM-YATAK SOL.par
3	SARI YATAK SOL.par
4	SARI YATAK SA V MONTAJ.asm
5	RM YATAK SAV KN100.par
6	SARI PABUÇ YENI.par
12	ÇAPAK SİYERİCI.asm
13	YAN BASKI.asm
14	KN100 KAM KAFA MİLİ.asm
18	Asm4.asm
19	SAG.asm
20	sdflaş.par
21	PSİTON BAĞLAMA MONTAJ.asm
23	DR_17_3_0_G63_DA_ML16A_FL8A_0_0_0_0_0_PI_A_F83C_0_0_M1.asm
24	YLMZ ENKODER LEMAZI.par
25	YLMZ ENKODER BAHLAMA TAKOZU.par
26	YLMZ SIVIC BAYKAMA.par
27	DORT KONTAK SIVIÇ.par
29	KN100 NUMARATOR.asm
31	63 KVA TRAF0.par
36	KAM YATAK MONTAJ.asm
38	KN100 HBA SAĞ KAPAK.asm
39	KN100 HBA SOL KAPAK.asm

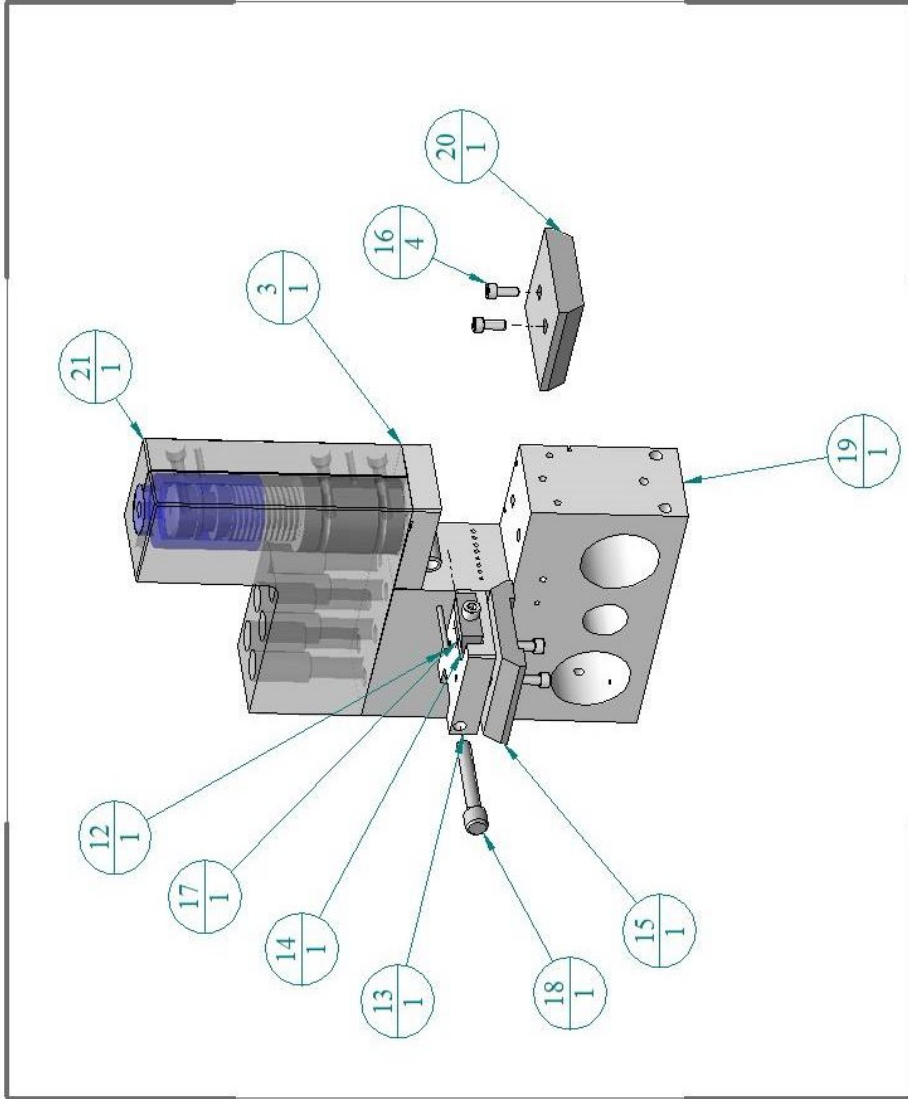

Item Number	File Name	Quantity
1*	TES UST SIKMA ANA TAKOZ 01.par	1
2*	UST SIKMA BOKUSU.par	1
3	MIL MONTAJ.asm	1
4*	50 34 11 emicid Sca yangiy emi KONI K.par	1
5*	SARI BURÇ.par	1
6*	KAPAMA PULU.par	1
7*	YEŞİ L YAY.par	1
8*	keş uci yatak maring konik.par	1
9*	Kantarcas Seslis-K-40-50X35X111.asm	1
10*	Kantarcas Seslis-K-75-4-5X 50X9_5 .asm	1
11*	Kantarcas Seslis-K-75-4-5X 50X14_8 .asm	1
12	ARA AÇMA PİMİ.par	1
13	Ayrık ALT YENİ 01.par	1
14	PARALELLİK LEMASI 01.par	1
15	UST CELİK.par	1
16	Im 8x20.par	4
17	DM10X45.par	1
18	PI M 12.par	1
19	ANA-YATAK-SOL-KN10 0.par	1
20	SARIPABUÇ YENİ .par	1
21	SAG.asm	1



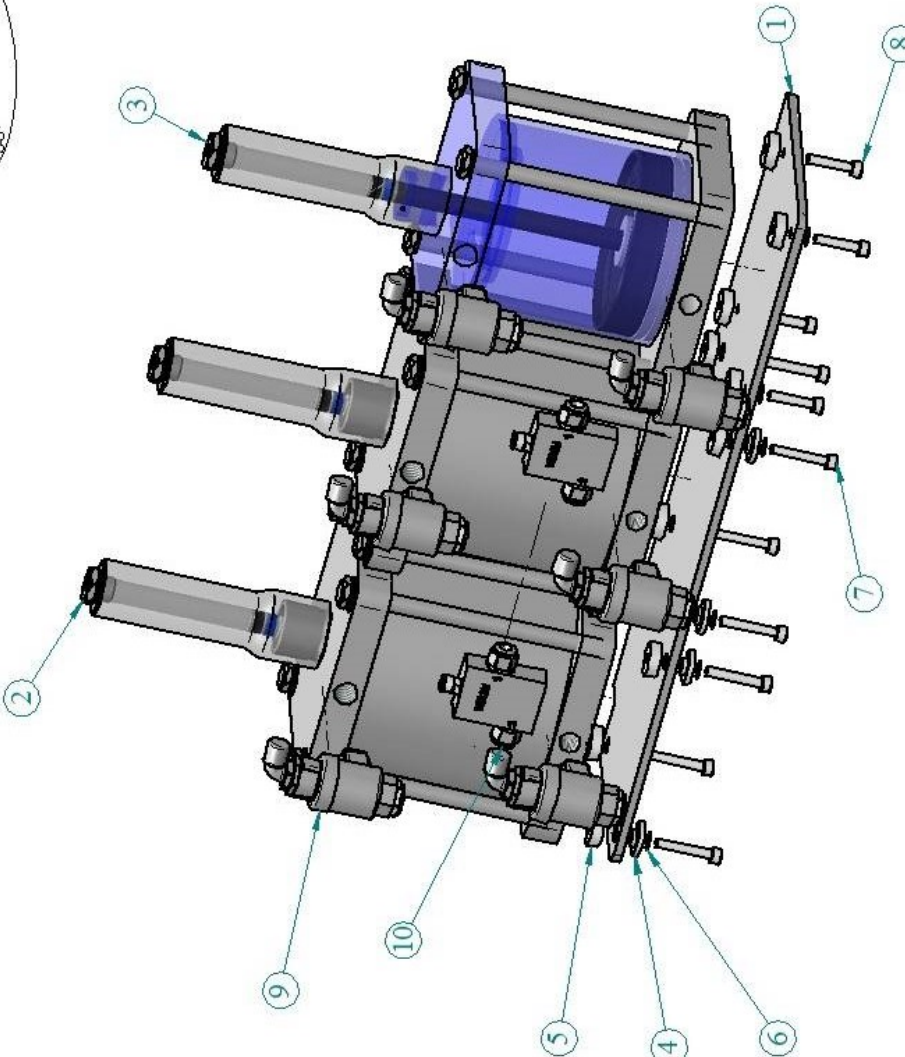



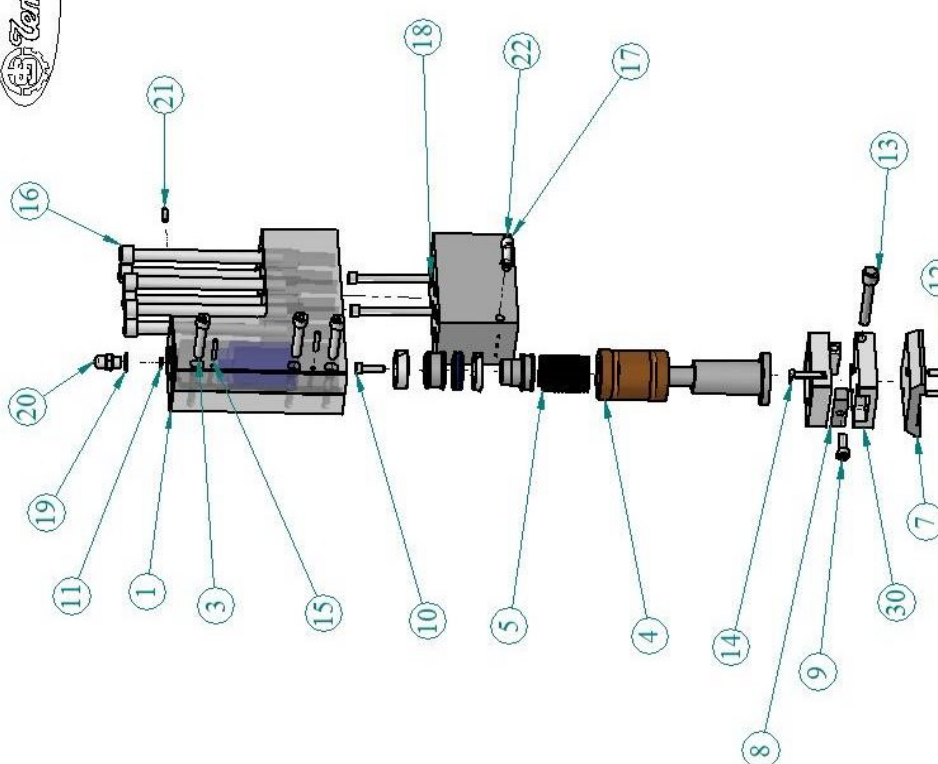

MALZEME	ADET	ÇİZEN	TARİH	UNVANI	ADI SOYADI	İMZA
		KONTROL		MAK.TEK.	Levent TEMEL	
ÖLÇEK		PARÇA ADI		MAK.MÜH.		
PISTON SACI MONTAJ .asm						RESİM NO.

POSITION	File Name
1	PSİTON SACI.par
2	200 piston montaj .asm
3	150X170 PISTON.asm
4	POLYEMİT-PUL-02.par
5	POLYEMİT-PUL-01.par
6	Plm8.par
7	IM8X50.par
8	IM8X40.par
9	CABUK EGSOZ 3-4 MONTAJ.as m
10	WARCOM WB2U 1-2 KILITLEME MONTAJ.as m

İtem Number	File Name
1	GOVDE SAG.par
2*	BORU.par
3	IM12X60.par
4	SARIBURCC.par
5	YEŞİL YAY.par
7	UST CELİK.par
8	PARALELLİK LEMASI/01.par
9	IM10X30.PAR
10	IM8X30 PAR
11	PUL-YAYLI-İM8.par
12	IM8X25.par
13	PI M 12.par
14	KAFA YAY DENEME.par
15	Stm6135.par
16	IM16X200.par
17	ANA TAKOZ-ALT.par
18	IM10X100.par
19	PuBk38.Par
20	NP35-39.par
21	STM6X20.par
22	DONER-DİRSEK 6-3-1-4 AVR-JS.par
23*	PISTON ANA MİL TEK PARÇA KONI K.par
24*	50.34.11 routing keçe /Bağı /eni KONI K.par
25*	Kaşa S SealB-K10-50X35X11.6 m
26*	AYAK UST TEK.par
27*	keçe ust./ayak routing konik.par
28*	Kaşa S SealB-K75-45X50X9.5 a em
29*	Kaşa S SealB-K75-45X50X11.6 a em
30	AYAK ALT TEK.par

MALZEME	ADET	ÇİZEN	TARİH	UNVANI	İMZA
				MAK.TEK.	ADI SOYADI
				MAK.MÜH.	Levent TEMEL
				PARÇA ADI	
				• SAG.asım	





RESİM NO. _____
 NOT: Beirlemlen Radüs ve Panhar 0.5 mm dir.



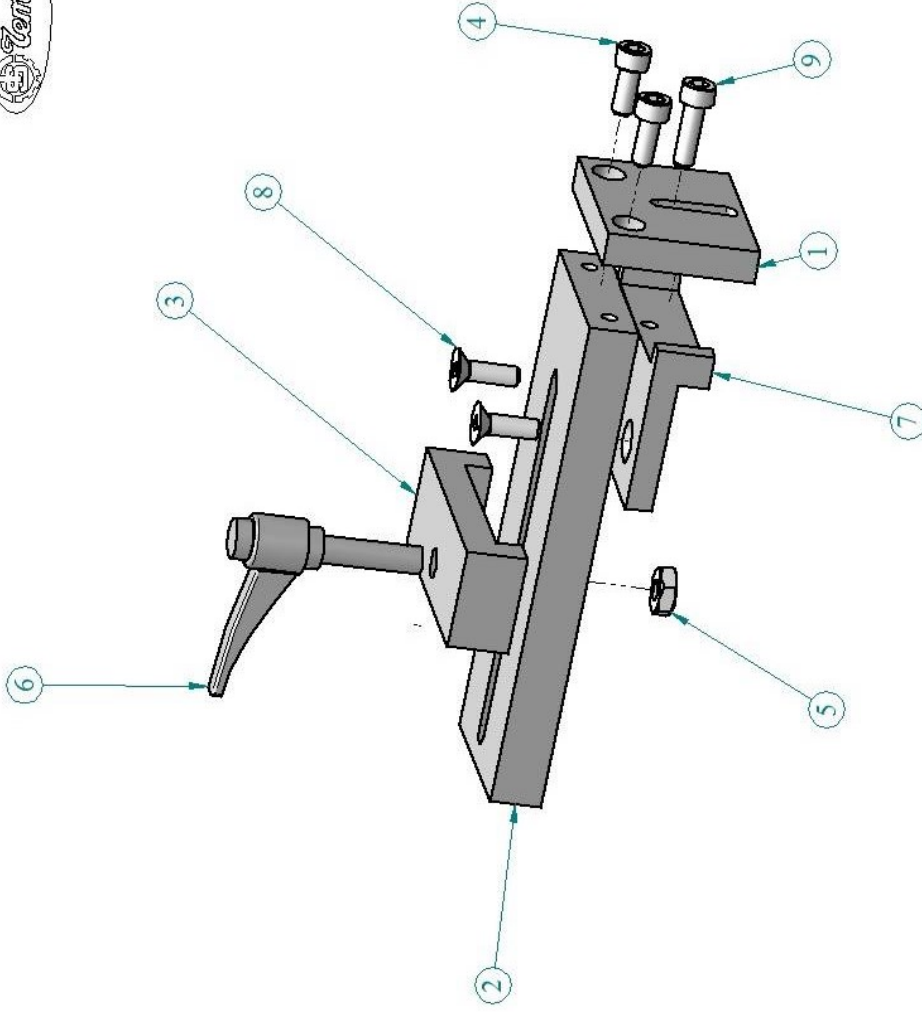

MALZEME	ADET	ÇİZEN	TARİH	ÜNİVANİ	ADI SOYADI	İMZA
ÖLÇEK		KONTROL		MAK. TEK.	Levent TEMEL	
		PARÇA ADI		MAK. MUH.		

TESTERE SIRT DAYAMA MONTAJ.asm

RESİM NO. _____
NOT: Belirtilen RADIUS ve PAHAR 0.8 mm dir.

Item Number	File Name
1	L ÖN PARÇA.par
2	L ÜST PARÇA.par
3	ÜST U.par
4	Im6x15.par
5	Sm8.par
6	BK M8 KOL.par
7	ALT LEMA.par
8	HBAL6X15.PAR
9	Im6x20.par

